

ENGINE - 4 CYLINDER

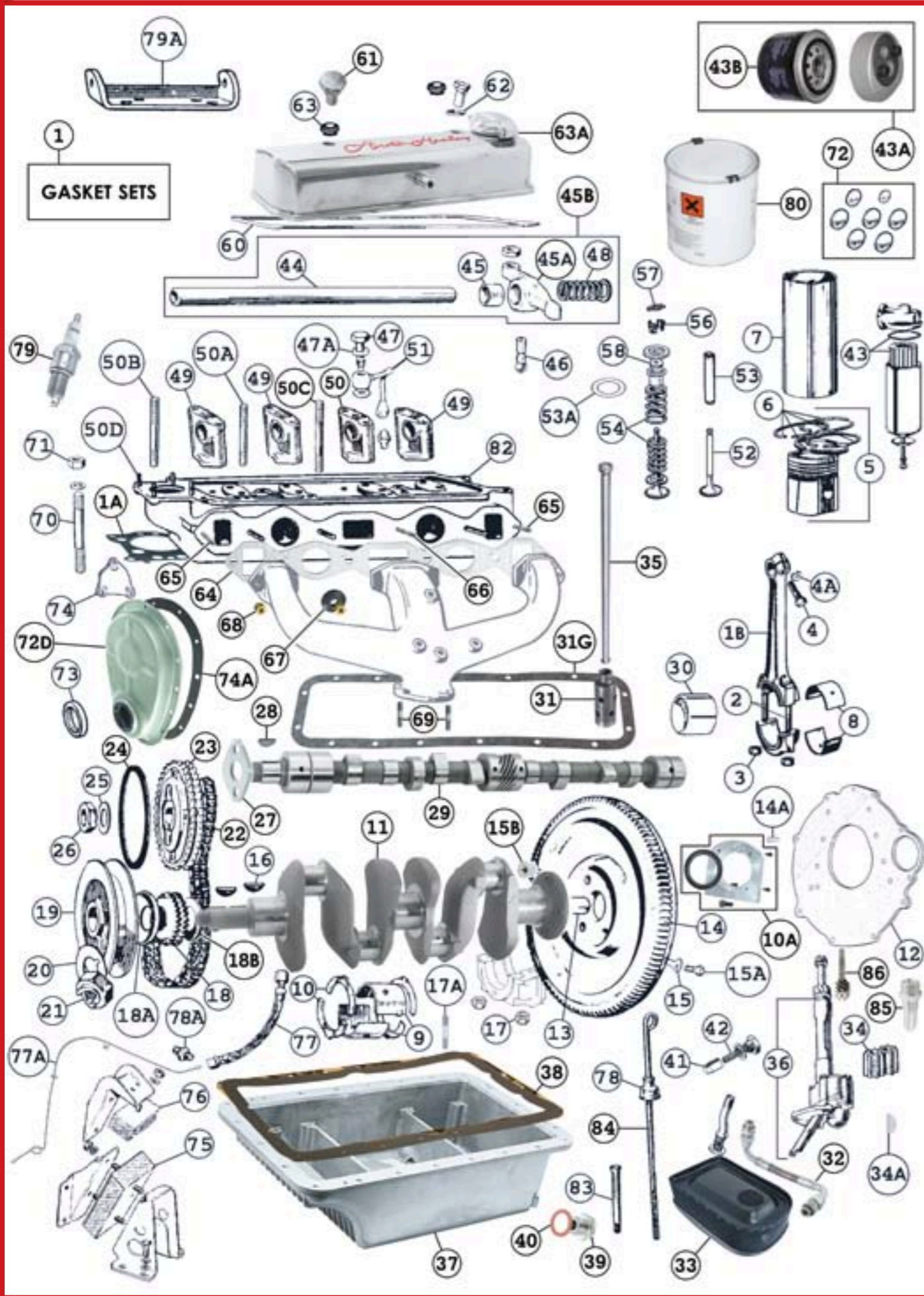

No.	Part No.	Description	Application	Notes	Price ex VAT
1	ENG401	GASKET SET-cylinder head	BN1-BN2		£41.95
1A	ENG401C	COMPETITION HEAD GASKET	BN1-BN2		£158.50
1	ENG402	GASKET SET-bottom end	BN1-BN2		£22.50
1B	ENG403C	STEEL CON ROD SET - H section - forged	BN1-BN2	USE.COM230	-
2	ENG404	BOLT-con rod-pair	BN1-BN2	SOLD AS PAIR	£23.25
3	ENG405	NUT-big end	BN1-BN2		£0.95
4	ENG406	BOLT-small end	BN1-BN2		£0.95
4A	ENG406A	WASHER-spring	BN1-BN2		£0.12
4	ENG406C	HEAVY DUTY BOLT SET - small end	BN1-BN2	SET OF 4	£3.85
5	ENG407	PISTON ASSY.(X4)STD.	BN1-BN2		£178.00
5	ENG408	PISTON ASSY.(X4)+.020'	BN1-BN2		£178.00
5	ENG409	PISTON ASSY.(X4)+.030'	BN1-BN2		£178.00
5	ENG410	PISTON ASSY.(X4)+.040'	BN1-BN2		£178.00
5	ENG411	PISTON ASSY.(X4)+.060'	BN1-BN2		£178.00
5	ENG412	PISTON ASSY.(X4)STD.	100M	8.6:1 HIGH COMPRESSION	£189.50
5	ENG412A	PISTON ASSY.(X4)+.020'	100M	8.6:1 HIGH COMPRESSION	£189.50
5	ENG412B	PISTON ASSY.(X4)+.030'	100M	8.6:1 HIGH COMPRESSION	£189.50
5	ENG412C	PISTON ASSY.(X4)+.040'	100M	8.6:1 HIGH COMPRESSION	£189.50
5	ENG412D	PISTON ASSY.(X4)+.060'	100M	8.6:1 HIGH COMPRESSION	£189.50
6	ENG412G	PISTON RING SET. std	BN1-BN2		£65.00
6	ENG412J	PISTON RING SET. std	BN1-BN2	TOTAL SEAL TYPE	£99.50
6	ENG412K	PISTON RING SET. std	100M	TOTAL SEAL TYPE	£99.50
6	ENG413	PISTON RING SET+.020'	BN1-BN2		£67.50
6	ENG414	PISTON RING SET+.030'	BN1-BN2		£67.50
6	ENG415	PISTON RING SET+.040'	BN1-BN2		£67.50
6	ENG416	PISTON RING SET+.060'	BN1-BN2		£67.50
7	ENG417	CYLINDER LINER	BN1-BN2		£20.50
8	ENG418	BIG END BEARING SET std.	BN1-BN2		£34.95
8	ENG419	BIG END BEARING SET +.010'	BN1-BN2		£34.95
8	ENG420	BIG END BEARING SET +.020'	BN1-BN2		£34.95
8	ENG421	BIG END BEARING SET +.030'	BN1-BN2		£34.95
8	ENG422	BIG END BEARING SET +.040'	BN1-BN2		£34.95
8	ENG422A	BIG END BEARING SET +.060'	BN1-BN2		£34.95
9	ENG423	MAIN BEARING SET std.	BN1-BN2		£39.95
9	ENG424	MAIN BEARING SET +.010'	BN1-BN2		£39.95
9	ENG425	MAIN BEARING SET +.020'	BN1-BN2		£39.95
9	ENG426	MAIN BEARING SET +.030'	BN1-BN2		£39.95
9	ENG427	MAIN BEARING SET +.040'	BN1-BN2		£39.95
10	ENG428	THRUST WASHER SET std.	BN1-BN2		£6.95
10	ENG429	THRUST WASHER SET +0.005'	BN1-BN2		£11.75
10A	ENG430	CONVERSION KIT-rear crank seal	BN1-BN2		£58.95
11	ENG431	CRANK SHAFT,REGROUND-exch.only	BN1-BN2	£1000 surcharge	£475.00
11	ENG432	CRANK SHAFT,REGROUND-outright	BN1-BN2		£1,100.00
12	ENG433A	ALUMINIUM BACK PLATE	BN1-BN2	USE WITH COM161	£85.00
12	ENG433B	ALUMINIUM BACK PLATE	BN1-BN2	6 CYL. HYD CLUTCH B/HOUSING	£85.00
13	ENG434	SPIGOT BUSH-crankshaft	BN1-BN2	USE.ENG634	-
14	ENG435	STARTER RING GEAR	BN1-BN2	USE.ENG635	-
14A	ENG435A	DOWEL- clutch cover	BN1-BN2		£1.50

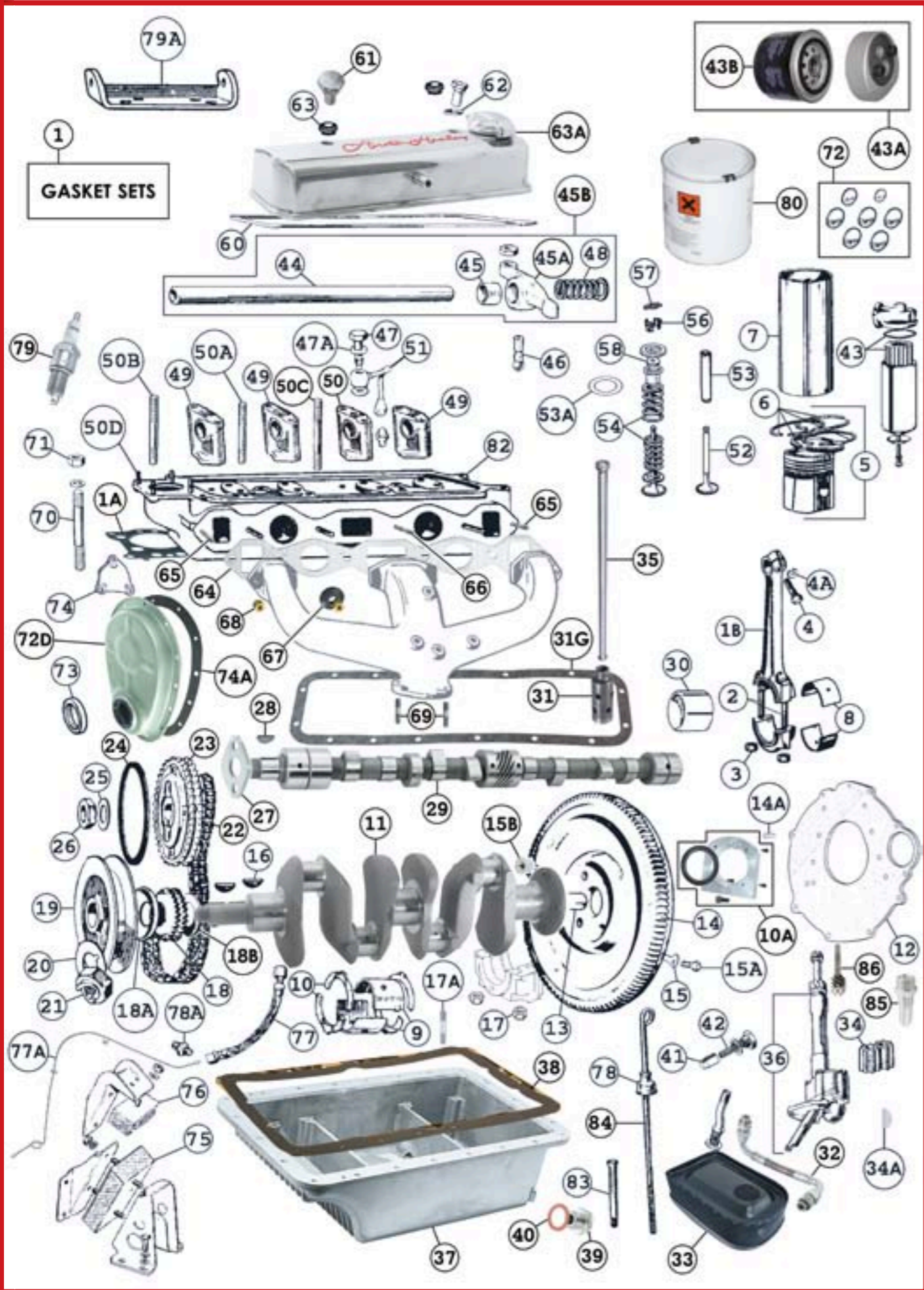

No.	Part No.	Description	Application	Notes	Price ex VAT
15	ENG436	LOCK WASHER-flywheel	BN1-BN2	USE.ENG636	-
15A	ENG437	BOLT-flywheel	BN1-BN2		£3.95
15B	ENG437A	NUT-flywheel bolt	BN1-BN2		£6.95
16	ENG438	WOODRUFF KEY-crank shaft	BN1-BN2	USE.ENG638	-
17	ENG439	NUT-main bearing cap-self lock	BN1.207106 ON		£1.65
17A	ENG439A	STUD-main bearing cap	BN1.207106 ON	HEAVY DUTY	£9.75
18	ENG440	CRANK GEAR-timing	BN1-BN2	USE.ENG640	-
18A	ENG441	OIL THROWER	BN1-BN2	USE.ENG641	-
18B	ENG441B	SHIM .006 - CRANKSHAFT	BN1-BN2	USE.ENG639	-
19	ENG442	PULLEY-crankshaft	BN1-BN2		£64.75
20	ENG445	LOCKWASHER-crank nut	BN1-BN2	USE.ENG645	-
21	ENG446	CRANK NUT	BN1-BN2	USE.ENG646	-
22	ENG447	TIMING CHAIN	BN1-BN2	USE.ENG648	-
22	ENG447C	TIMING CHAIN - COMPETITION	BN1-BN2	USE.ENG648C	-
22	ENG447R	TIMING CHAIN - COMPETITION H/DUTY	BN1-BN2	USE.ENG648R	-
23	ENG448	CAM GEAR-timing(with rivets)	BN1-BN2	USE OWN PLATES	£74.25
24	ENG450	TENSIONER RING-camgear	BN1-BN2		£2.35
25	ENG452	LOCKWASHER-cam nut	BN1-BN2	USE.ENG652	-
26	ENG453	NUT-camgear	BN1-BN2	USE.ENG653	-
27	ENG454	RETAINING PLATE-camshaft	BN1-BN2	USE.ENG654	-
28	ENG455	WOODRUFF KEY-camshaft	BN1-BN2	USE.ENG655	-
29	ENG456	CAMSHAFT-LE MANS-NEW-OUTRIGHT	BN1-BN2	SUITABLE FOR ALL	£395.00

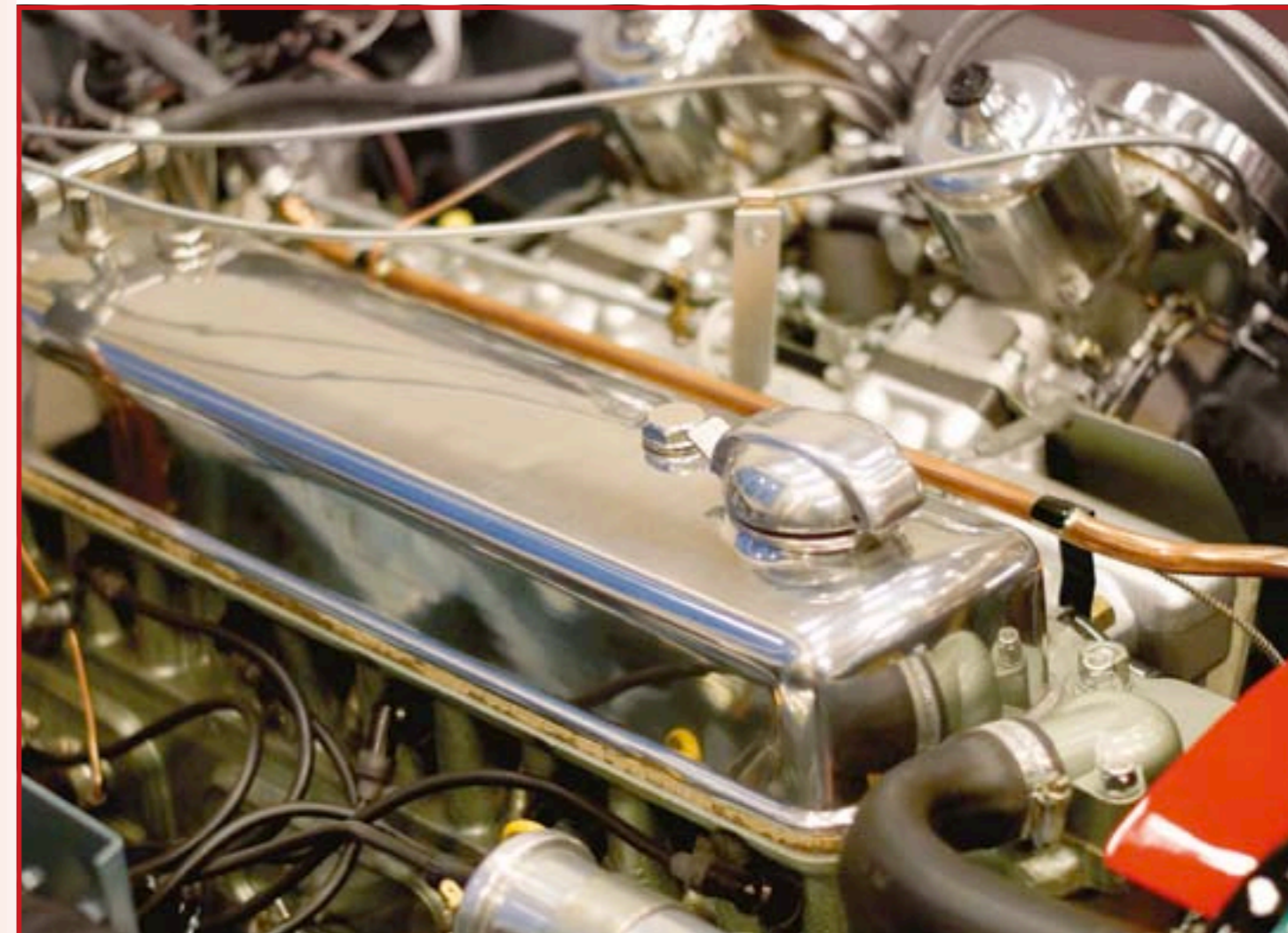

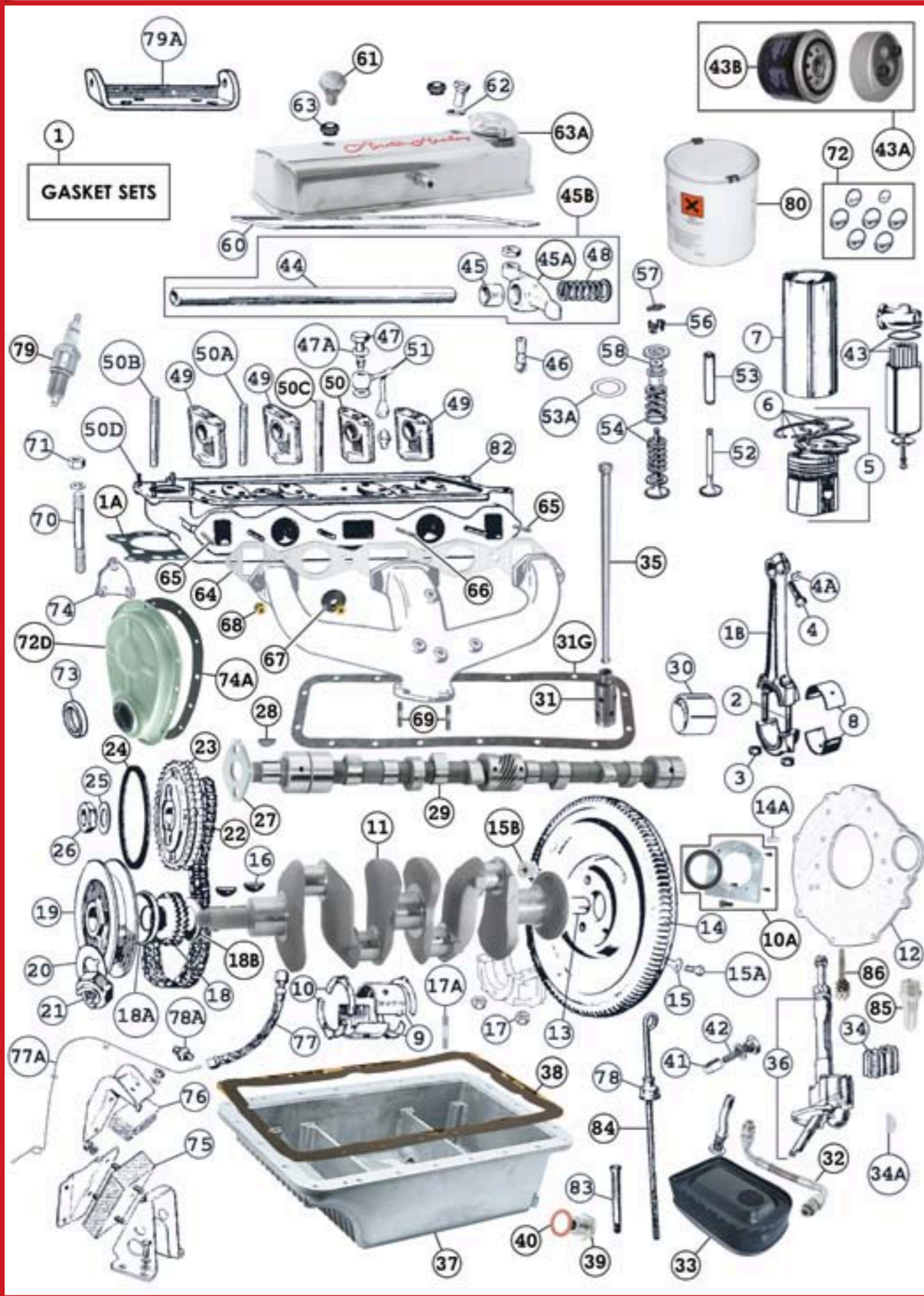

No.	Part No.	Description	Application	Notes	Price ex VAT
29	ENG456F	CAMSHAFT-FAST ROAD-NEW-OUTRIGHT	BN1-BN2		£395.00
30	ENG459	BEARING SET-camshaft	BN1-BN2		£37.50
31	ENG460	CAM FOLLOWER	BN1-BN2		£8.50
31	ENG460C	CAM FOLLOWER-MODIFIED	BN1-BN2	INCREASED LUBRICATION	£10.80
31	ENG461	BUCKET CAM FOLLOWER-SET	BN1-BN2	MUST USE TUBULAR PUSH RODS	£225.00
31G	ENG461G	TAPPET SIDE COVER GASKET	BN1-BN2		£3.85
32	ENG462	PIPE-oil delivery	BN1-BN2	FLEXIBLE-NON STD	£36.95
33	ENG463	OIL STRAINER	BN1-BN2		£41.75
34	ENG464	GEAR-driving	BN1-BN2	USE.ENG675	-
34	ENG464A	GEAR-driven	BN1-BN2	USE.ENG677	-
34A	ENG464B	OIL PUMP GEAR KEY	BN1-BN2	USE.ENG676A	-
35	ENG465C	TUBULAR PUSH ROD-uprated	BN1-BN2	LIGHTER & STRONGER	£13.85
36	ENG466	OIL PUMP-less drive shaft	BN1-BN2		£275.00
36A	ENG466A	OIL PUMP DRIVE SHAFT	BN1-BN2		£125.00
37	ENG467	ALUMINIUM OIL SUMP	BN1-BN2	USE.COM194F	-
38	ENG468	GASKET-oil sump	BN1-BN2		£6.95
39	ENG469	DRAIN PLUG-oil sump	BN1-BN2	USE.ENG669	-
39	ENG469M	DRAIN PLUG - MAGNETIC	BN1-BN2	USE.ENG669M	-
40	ENG470	WASHER-drain plug	BN1-BN2	USE.ENG670	-
41	ENG480	VALVE-oil pressure release	BN1-BN2		£2.95
42	ENG481	SPRING-oil pressure release	BN1-BN2		£1.75
43	ENG487	OIL FILTER ELEMENT-felt	BN1-BN2	USE.ENG687	-
43	ENG488	OIL FILTER ELEMENT-paper	BN1-BN2	USE.ENG688	-
43A	ENG489	KIT-spin off filter	BN1-BN2	DIRECT TO BLOCK	£30.75
43B	ENG489F	FILTER-spin off type	A/R	USE.ENG698F	-
44	ENG500	ROCKER SHAFT	BN1-BN2		£27.50
45	ENG501	BUSHES-rockershaft	BN1-BN2	USE.ENG701	-
45A	ENG501A	ROCKER ARM - with bush	BN1-BN2	USE.ENG705	-
45B	ENG502	ROCKER SHAFT ASSY - reconditioned	BN1-BN2	EXCHANGE ONLY £200 surcharge	£129.95
46	ENG503	SCREW-rocker adjusting	BN1-BN2		£9.45
47	ENG504	BANJO BOLT - oil feed	BN1-BN2		£7.25
47A	ENG505	WASHER-banjo bolt	BN1-BN2	USE.ENG710	-
48	ENG506	SPRING-rocker arm spacing	BN1-BN2	USE.ENG706	-
49	ENG507	ROCKER PEDESTAL-plain	BN1-BN2	USE.ENG707	-
50	ENG508	ROCKER PEDESTAL-tapped hole	BN1-BN2		£22.50
50A	ENG509	STUD-rocker shaft-short	BN1-BN2		£2.25
50B	ENG510	STUD-rocker shaft-long	BN1-BN2		£2.15
50C	ENG511	STUD-rocker cover	BN1-BN2		£2.15
50D	ENG512	STUD-thermostat housing	BN1-BN2		£1.75
51	ENG515	PIPE-oil feed	BN1-BN2		£22.50
52	ENG520	VALVE-inlet	BN1-BN2	USE.ENG720	-



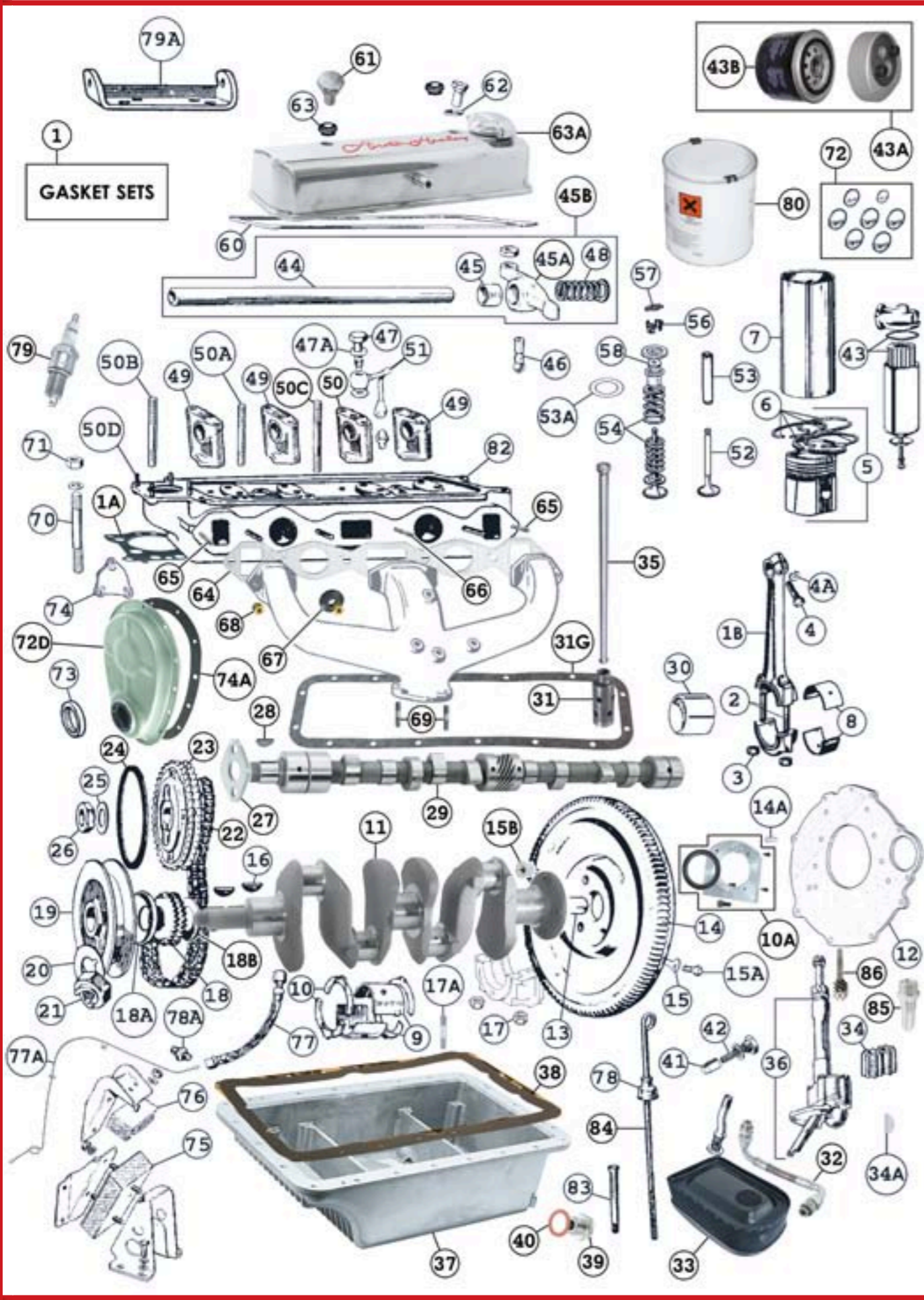

No.	Part No.	Description	Application	Notes	Price ex VAT
52	ENG521	VALVE-exhaust	BN1-BN2		£6.50
53	ENG522	GUIDE-inlet valve	BN1-BN2		£2.55
53	ENG522B	GUIDE-inlet valve-bronze	BN1-BN2	BRONZE	£5.95
53	ENG523	GUIDE-exhaust valve	BN1-BN2		£2.55
53	ENG523B	GUIDE-exhaust valve-bronze	BN1-BN2	BRONZE	£6.75
53A	ENG524	SHIM-valve spring .010"	BN1-BN2	USE.ENG727	-
53A	ENG524A	SHIM-valve spring .015"	BN1-BN2	USE.ENG727A	-
54	ENG525	VALVE SPRING SET	BN1-BN2		£26.75
54	ENG525HD	HEAVY DUTY VALVE SPRING SET	BN1-BN2	MUST USE 3000 TOP CAPS	£22.50
56	ENG533	COLLETS,valve(pr)	BN1-BN2	USE.ENG733	-
57	ENG534	CLIP,valve collets	BN1-BN2	USE.ENG734	-
58	ENG535	OIL SEAL-valve stem	BN1-BN2		£1.25
59	ENG536	ROCKER COVER-alloy with QA cap	BN1-BN2	ENGRAVED	£129.95
60	ENG539	GASKET-rocker cover	BN1-BN2		£2.50
61	ENG540	CAP NUT-rocker cover(S.S.)	BN1-BN2		£9.95
62	ENG541	CUP WASHERS-rocker cover(S.S.)	BN1-BN2	USE.ENG741	-
63	ENG542	RUBBER BUSH-rocker cover	BN1-BN2	USE.ENG742	-
63A	ENG543	OIL FILLER CAP-rocker cover	BN1-BN2		£42.50
64	ENG546	GASKET-manifold to head	BN1-BN2		£2.95
64	ENG546C	BIG BORE GASKET-manifold to head	BN1-BN2	LARGER PORT HOLES	£11.50
65	ENG548	STUD.SHORT-manifold to head	BN1-BN2		£1.10
66	ENG549	STUD.LONG-manifold to head	BN1-BN2		£1.30
67	ENG550	YOKE.WASHER-manifold to head	BN1-BN2		£1.60
68	ENG554	BRASS NUT-manifold to head	BN1-BN2		£1.25
69	ENG560	STUD-exhst.manifold to d/pipe	BN1-BN2	USE.EXS112	-
70	ENG561	STUD-cylinder head	BN1-BN2		£4.55
70	ENG561C	STUD SET-cylinder head	BN1-BN2	COMPETITION - INC NUTS	£74.50
71	ENG562	NUT-cylinder head	BN1-BN2		£1.65
72	ENG570	CORE PLUG SET	BN1-BN2		£4.95
72D	ENG575	TIMING COVER - Lip seal conversion EXCHANGE	BN1-BN2	EXCH ONLY £150 surcharge	£72.50
73	ENG577	OIL SEAL-timing cover	BN1-BN2		£3.85
74	ENG578	BLANKING PLATE-water gallery	BN1-BN2		£23.90
74A	ENG579	GASKET-timing cover	BN1-BN2		£2.25
75	ENG580	ENGINE MOUNTING	BN1-BN2	USE.ENG800	-
76	ENG581	REBOUND-engine mounting	BN1-BN2	USE.ENG801	-
77	ENG582	FLEXIBLE PIPE-oil pressure	BN1-BN2	USE.ENG805	-
77A	ENG582B	PIPE-oil pressure-to gauge-LHD	BN1-BN2		£16.00
78	ENG583	DUST SEAL-dip stick	BN1-BN2		£1.39
78A	ENG585	UNION - oil pressure hose	BN1-BN2		£11.50
79	ENG587	SPARK PLUG	BN1-BN2	USE.ELI145	-
79A	ENG588	DYNAMO BRACKET	BN1-BN2		£35.00
80	ENG590	ENGINE PAINT-(1 quart tin)	BN1-BN2	USE.ENG810	-
82	ENG592	CYLINDER HEAD-aluminium	BN1-BN2	WITH VALVES ETC.	£1,995.00
82	ENG592A	CYL HEAD-recon-unleaded-outright	BN1-BN2	INC VALVES ETC	£1,495.00
82	ENG592FR	FAST ROAD CYLINDER HEAD-aluminium	BN1-BN2	INC VALVES ETC	£2,550.00
82	ENG592RA	FULL RACE CYLINDER HEAD-aluminium	BN1-BN2	INC VALVES ETC	£2,750.00
83	ENG593	TUBE-oil dip stick	BN1-BN2		£5.70
84	ENG594	DIP STICK	BN1-BN2		£44.95
85	ENG595	TACHO DRIVE BUSH	BN1-BN2		£32.50
86	ENG596	TACHO DRIVE GEAR	BN1-BN2		£75.00

ENGINE - 6 CYLINDER - 1

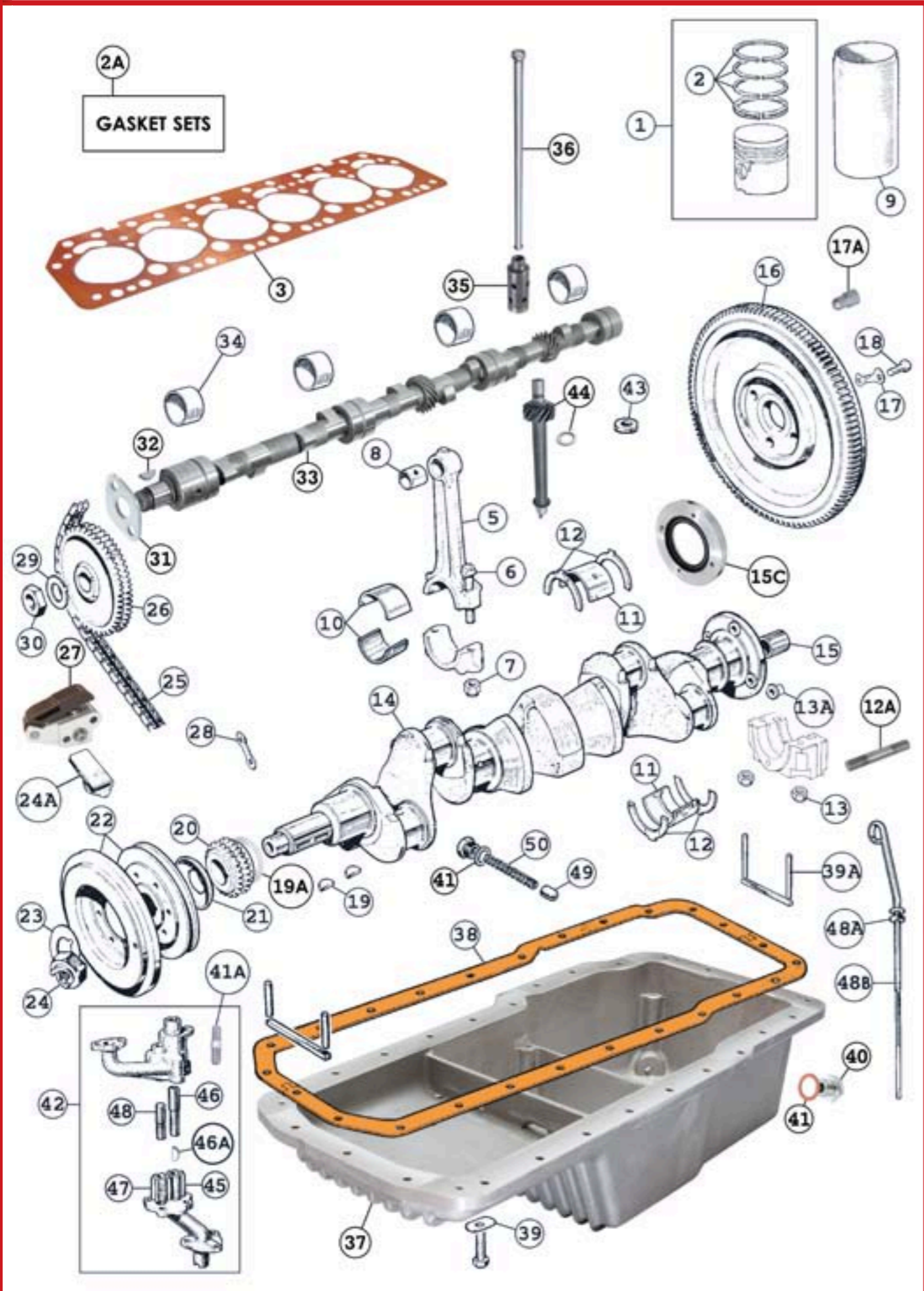

No.	Part No.	Description	Application	Notes	Price ex VAT
1	ENG599	PISTON ASSY.(set of 6)STD.	BN4.ENG.40501 ON		£298.00
1	ENG600	PISTON ASSY.(set of 6)+.020'	BN4.ENG.40501 ON		£298.00
1	ENG600A	PISTON ASSY.(set of 6)+.030'	BN4.ENG.40501 ON		£298.00
1	ENG600B	PISTON ASSY.(set of 6)+.040'	BN4.ENG.40501 ON		£298.00
1	ENG600C	PISTON ASSY.(set of 6)+.060'	BN4.ENG.40501 ON		£298.00
2	ENG601	PISTON RING SET.std.	BN4-BN6		£74.95
2	ENG601A	PISTON RING SET.+020'	BN4-BN6		£74.95
2	ENG601B	PISTON RING SET.+030'	BN4-BN6		£74.95
2	ENG601C	PISTON RING SET.+040'	BN4-BN6		£74.95
2A	ENG601J	GASKET SET-cylinder head	BN4-BN4.48862		£42.50
2A	ENG602	GASKET SET-cylinder head	BN4-BJ8		£35.95
3	ENG602A	GASKET-cylinder head	BN4-BJ8		£20.95
3	ENG602C	COMPETITION STEEL GASKET-cylinder head	BN4-BJ8		£199.50
3	ENG602P	GASKET-cylinder head-HIGH QUALITY UK MADE	BN4-BJ8	HIGH QUALITY UK MANUFACTURED	£75.00
2A	ENG603	GASKET SET-bottom end-PAYEN	BN4-BJ8		£20.95
5	ENG604A	CONNECTING ROD-used	BN4-BJ8		£47.50
5	ENG604C	STEEL CON ROD SET - H section - forged		USE.COM234	-
6	ENG605	BOLT-big end	BN4-BJ8		£11.50
7	ENG606	NUT-big end bolt	BN4-BJ8		£1.75
7	ENG606C	NUT-big end bolt-COMPETITION	BN4-BJ8	COMPETITION-ARP	£2.50
8	ENG607	BUSH-small end(set)	BN4-BJ8		£10.25
1	ENG608	PISTON ASSY.(X6)STD.	BT7-BJ8	17731 TYPE	£191.50
1	ENG608A	PISTON ASSY.(set of 6)Std.	BT7-BJ8	17731 HEPOLITE	£445.00
1	ENG609	PISTON ASSY.(X6)+.020'	BT7-BJ8	17731 TYPE	£191.50
1	ENG609A	PISTON ASSY.(set of 6)+.020'	BT7-BJ8	17731 HEPOLITE	£445.00
1	ENG610	PISTON ASSY.(x6)+.030'	BT7-BJ8	17731 TYPE	£191.50
1	ENG611	PISTON ASSY.(x6)+.040'	BT7-BJ8	17731 TYPE	£191.50
1	ENG612	PISTON ASSY.(X6)+.060'	BT7-BJ8		£191.50
2	ENG613	PISTON RING SET.std.	BT7-BJ8	ORIGINAL PISTONS	£72.00
2	ENG613A	PISTON RING SET.std.	BT7-BJ8	17731 PISTONS	£72.00
2	ENG614	PISTON RING SET.+020'	BT7-BJ8	ORIGINAL PISTONS	£72.00
2	ENG614A	PISTON RING SET.+020'	BT7-BJ8	17731 PISTONS	£72.00
2	ENG615	PISTON RING SET.+030'	BT7-BJ8	ORIGINAL PISTONS	£72.00
2	ENG615A	PISTON RING SET.+030'	BT7-BJ8	17731 PISTONS	£72.00
2	ENG616	PISTON RING SET.+040'	BT7-BJ8	ORIGINAL PISTONS	£72.00
2	ENG616A	PISTON RING SET.+040'	BT7-BJ8	17731 PISTONS	£72.00
2	ENG617	PISTON RING SET.+060'	BT7-BJ8	ORIGINAL PISTONS	£72.00
2	ENG617A	PISTON RING SET.+060'	BT7-BJ8	17731 PISTONS	£72.00
9	ENG618	CYLINDER LINER	BT7-BJ8		£21.40
9	ENG618A	CYLINDER LINER	BN4-BN6		£23.50
10	ENG619A	BIG END BEARING SET.Std.	BN4-BJ8		£42.50
10	ENG620A	BIG END BEARING SET.+010	BN4-BJ8		£42.50
10	ENG621A	BIG END BEARING SET.+020'	BN4-BJ8		£42.50
10	ENG622A	BIG END BEARING SET.+030'	BN4-BJ8		£42.50
10	ENG622B	BIG END BEARING SET.+040'	BN4-BJ8		£42.50
10	ENG623A	BIG END BEARING SET.+060'	BN4-BJ8		£42.50

ENGINE - 6 CYLINDER - 1

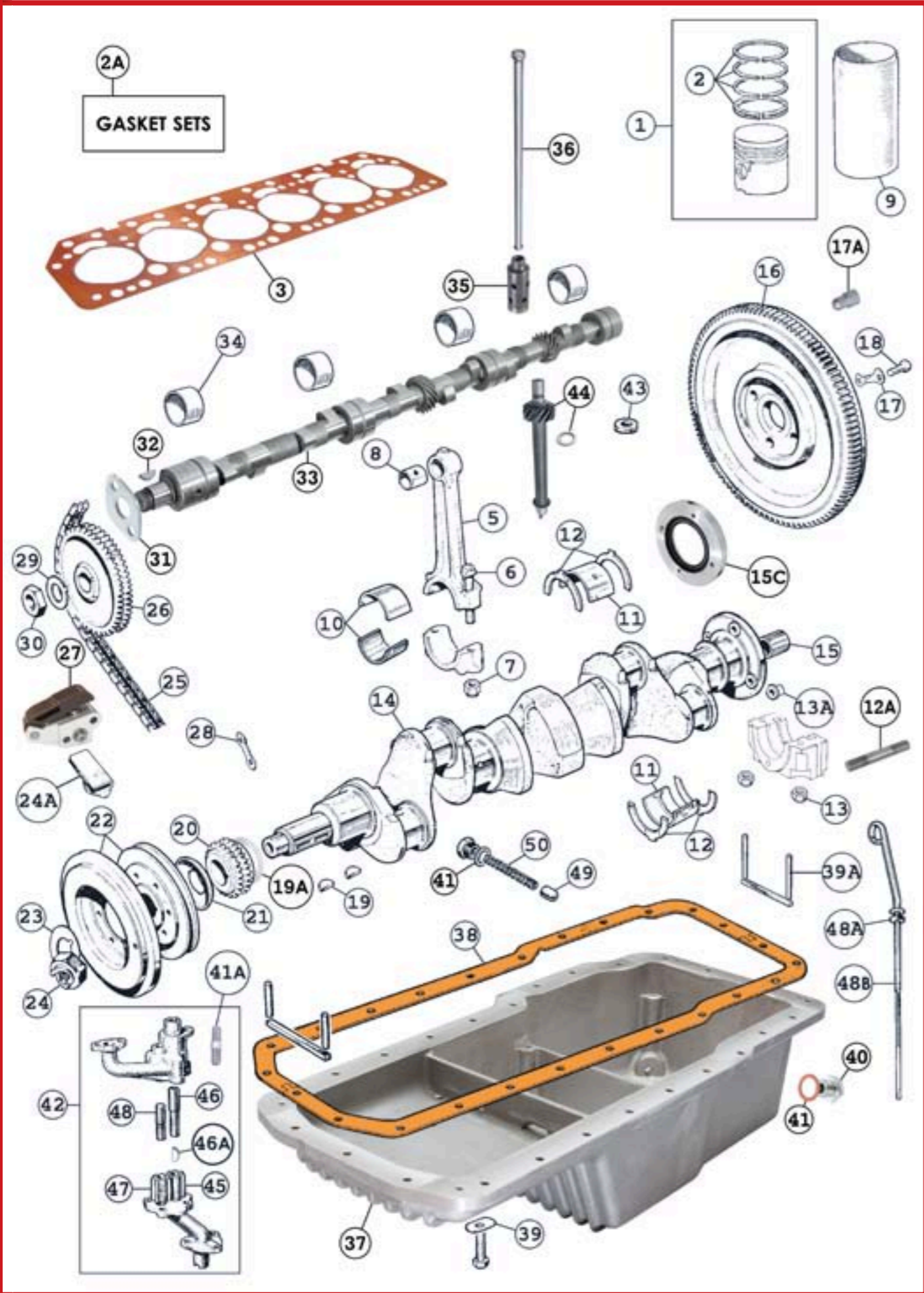

No.	Part No.	Description	Application	Notes	Price ex VAT
11	ENG624	MAIN BEARING SET.Std.	BN4-BJ8		£46.50
11	ENG625	MAIN BEARING SET+.010'	BN4-BJ8		£46.50
11	ENG626	MAIN BEARING SET+.020'	BN4-BJ8		£46.50
11	ENG627	MAIN BEARING SET+.030'	BN4-BJ8		£46.50
11	ENG627A	MAIN BEARING SET+.040'	BN4-BJ8		£46.50
12	ENG628	THRUST WASHER SET.Std.	BN4-BJ8		£6.75
12A	ENG630	MAIN BEARING STUD	BN4-BJ8		£6.05
12A	ENG630C	COMPETITION MAIN BEARING STUD	BN4-BJ8	WASTED DESIGN	£7.95
13	ENG631	NUT-main bearing cap	BN4-BJ8		£0.99
13	ENG631C	MAIN NUT AND WASHER SET	BN4-BJ8	HEAVY DUTY-ARP	£17.25
13A	ENG632	NUT-flywheel bolt	BN4-BJ8		£4.25
14	ENG633	CRANKSHAFT-REGROUND-exchange	BN4-BJ8	INC BEARINGS £300 surcharge	£565.00
14	ENG633A	CRANKSHAFT-REGROUND-outright	BN4-BJ8	OUTRIGHT SALE - INC BRGS	£695.00
15	ENG634	SPIGOT BUSH-crankshaft	BN4-BJ8		£2.79
15C	ENG634C	CONVERSION KIT-rear crank seal	BN4-BJ8	USE.COM162	-
16	ENG635	STARTER RING GEAR	BN4-BJ8		£33.95
16	ENG635R	LIGHTWEIGHT STARTER RING GEAR	BN1-BJ8		£68.50
17	ENG636	LOCKWASHER-flywheel	BN4-BJ8		£1.25
17A	ENG636A	DOWEL-flywheel	BN1-BJ8		£1.65
18	ENG637	BOLT-flywheel	BN4-BJ8		£1.65
18	ENG637C	HEAVY DUTY FLYWHEEL BOLT	BN4-BJ8	ARP 12 POINT HEAD	£4.30
19	ENG638	WOODRUFF KEY-crankshaft(2-car)	BN4-BJ8		£0.87
19A	ENG639	SHIM .006 - CRANKSHAFT	BN4-BJ8		£0.89
20	ENG640	CRANK GEAR-timing	BN1-BJ8		£28.95
21	ENG641	OIL THROWER	BN4-BJ8		£3.95
22	ENG643	CRANK PULLEY & DAMPER	BN4-BJ8	3/8" PULLEY	£296.75
23	ENG645	LOCKWASHER-crankshaft nut	BN4-BJ8		£3.50
24	ENG646	NUT-crankshaft-starter dog	BN1-BJ8		£15.75
24A	ENG647	DAMPER - timing chain	MK2-MK3		£17.75
25	ENG648	TIMING CHAIN	BN4-BJ8		£8.25
25	ENG648C	TIMING CHAIN - COMPETITION	BN1-BJ8	UPRATED	£28.50
25	ENG648R	TIMING CHAIN - FULL RACE H/DUTY	BN1-BJ8	FULL RACE HEAVY DUTY	£38.50
26	ENG649	CAM GEAR	BN4-BJ8		£64.50
26	ENG649V	CAM GEAR STEEL-VERNIER	BN1-BJ8	FOR ACCURATE CAM TIMING	£145.00
27	ENG650	TENSIONER-timing chain	BN4-BJ8		£8.95
27	ENG650H	HYDRAULIC TENSIONER-timing chain	BN4-BJ8		£69.95
28	ENG651	LOCK WASHER-tensioner	BN4-BJ8		£0.59
29	ENG652	LOCKWASHER-camshaft	BN4-BJ8		£1.35
30	ENG653	NUT-camshaft	BN4-BJ8		£4.95
31	ENG654	RETAINING PLATE-camshaft	BN1-BJ8		£12.95
32	ENG655	WOODRUFF KEY-camshaft	BN4-BJ8		£1.05

ENGINE - 6 CYLINDER - 1

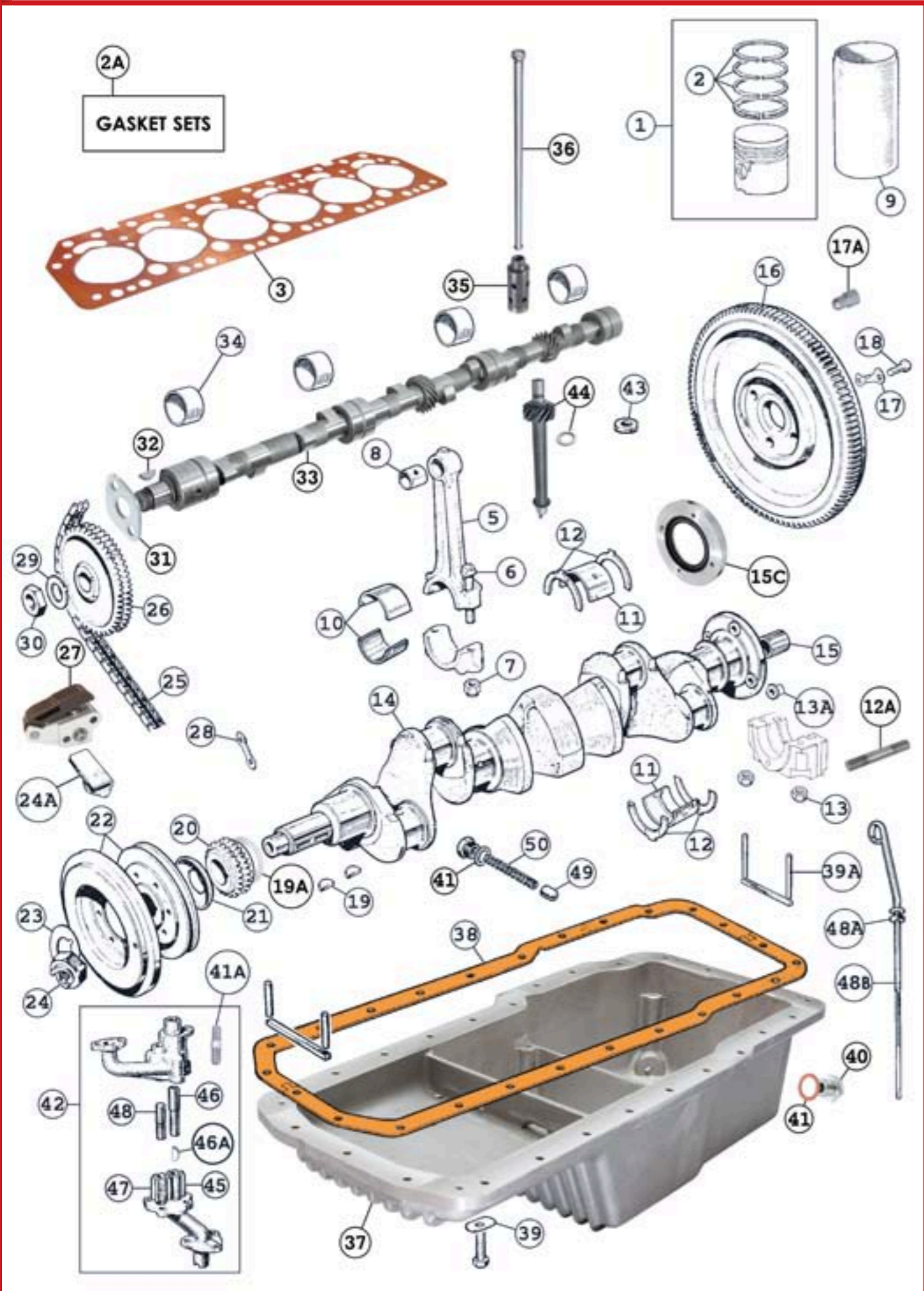

No.	Part No.	Description	Application	Notes	Price ex VAT
33	ENG656	CAMSHAFT-(new)	BN4-BJ8		£410.00
33	ENG656AHP1	CAMSHAFT KIT- FAST ROAD-AHP1	BN4-BJ8	INC FOLLOWERS+LUBE	£565.00
33	ENG656AHP2	CAMSHAFT KIT- RALLY SPEC-AHP2	BN4-BJ8	INC FOLLOWERS+LUBE	£595.00
33	ENG656AHP3	CAMSHAFT KIT - RACE 1 SPEC-AHP3	BN4-BJ8	INC FOLLOWERS+LUBE	£595.00
33	ENG656AHP4	CAMSHAFT KIT - RACE 2 SPEC-AHP4	BN4-BJ8	INC FOLLOWERS+LUBE	£595.00
33	ENG656AHP5	CAMSHAFT KIT - RACE 3 SPEC-AHP5	BN4-BJ8	INC FOLLOWERS+LUBE	£595.00
33	ENG656B	CAMSHAFT - BILLET (new)	BN4-BJ8	REQUIRES FINISHING	£295.00
33	ENG656F	CAMSHAFT - FAST ROAD SPEC.	BN4-BJ8		£449.50
33	ENG656R	CAMSHAFT - RALLY SPEC.	BN4-BJ8		£475.00
33	ENG656UR	CAMSHAFT - FULL RACE.	BN4-BJ8	SERIOUS COMPETITION ONLY	£475.00



These are a completely new design using modern technological advancements. No old cam data has been used from the old "works" designs so these really are the most modern high tech cam designs available today.

Manufactured from EN40B the best steel for camshafts. When nitrided it gives a surface hardness and finish similar to chilled iron and is used for many modern motorsport camshafts.

Extensive testing has been carried out to prove they perform better than any other Healey camshaft available. The modern design allows vastly improved volumetric filling efficiency meaning more power!!

With completely new ramp geometry and reduced valve lash they drastically decrease mechanical stress to the cam lobes and whole of the valve train. Kinder to your engine yet delivering more torque and BHP.

34	ENG658	BEARING SET-camshaft	BN4-BJ8		£28.00
35	ENG660	CAM FOLLOWER	BN4-BJ8		£8.25
35	ENG660C	CAM FOLLOWER-MODIFIED	BN4-BJ8	INCREASED LUBRICATION	£9.75
36	ENG661	PUSH ROD	BN4-BJ8		£2.60
37	ENG664	OIL SUMP - ALUMINIUM	BN4-BJ8	USE.COM195	-
38	ENG666	GASKET SET-oil sump	BN4-BJ8		£7.95
39	ENG667	WASHER-oil sump	BN4-BJ8		£0.32
39A	ENG668	FELT PLUG	BN4-BJ8		£2.55
40	ENG669	DRAIN PLUG-oil sump	BN4-BJ8		£2.95
40	ENG669M	DRAIN PLUG - MAGNETIC	BN4-BJ8	INC WASHER	£9.75
41	ENG670	WASHER-drain plug	BN4-BJ8		£0.39
41A	ENG671	STUD - oil pump	BN4-BJ8		£2.30
42	ENG672	OIL PUMP	BN4-BJ8		£106.50
42	ENG672H	OIL PUMP-High Capacity	BN4-BJ8	ROTARY TYPE	£129.00
43	ENG673	THRUST WASHER-oil pump drive	BN4-BJ8		£4.50
44	ENG674	SPINDLE & WASHER-pump drive	BN4-BJ8	INC WASHER	£79.95
45	ENG675	GEAR-driving	BN4-BJ8		£18.95
46	ENG676	SHAFT-driving gear	BN4-BJ8		£11.75
46A	ENG676A	OIL PUMP GEAR KEY	BN4-BJ8		£0.85
47	ENG677	GEAR-driven	BN4-BJ8		£18.95
48	ENG678	SHAFT-driven gear	BN4-BJ8		£6.25
48A	ENG680	WASHER-rubber-dipstick	BN4-BJ8		£0.39
48B	ENG681	DIP STICK	BN4-BJ8(E)29K-H278		£38.50
48B	ENG682	DIP STICK	BJ8(E)29K-H279-ON		£38.50

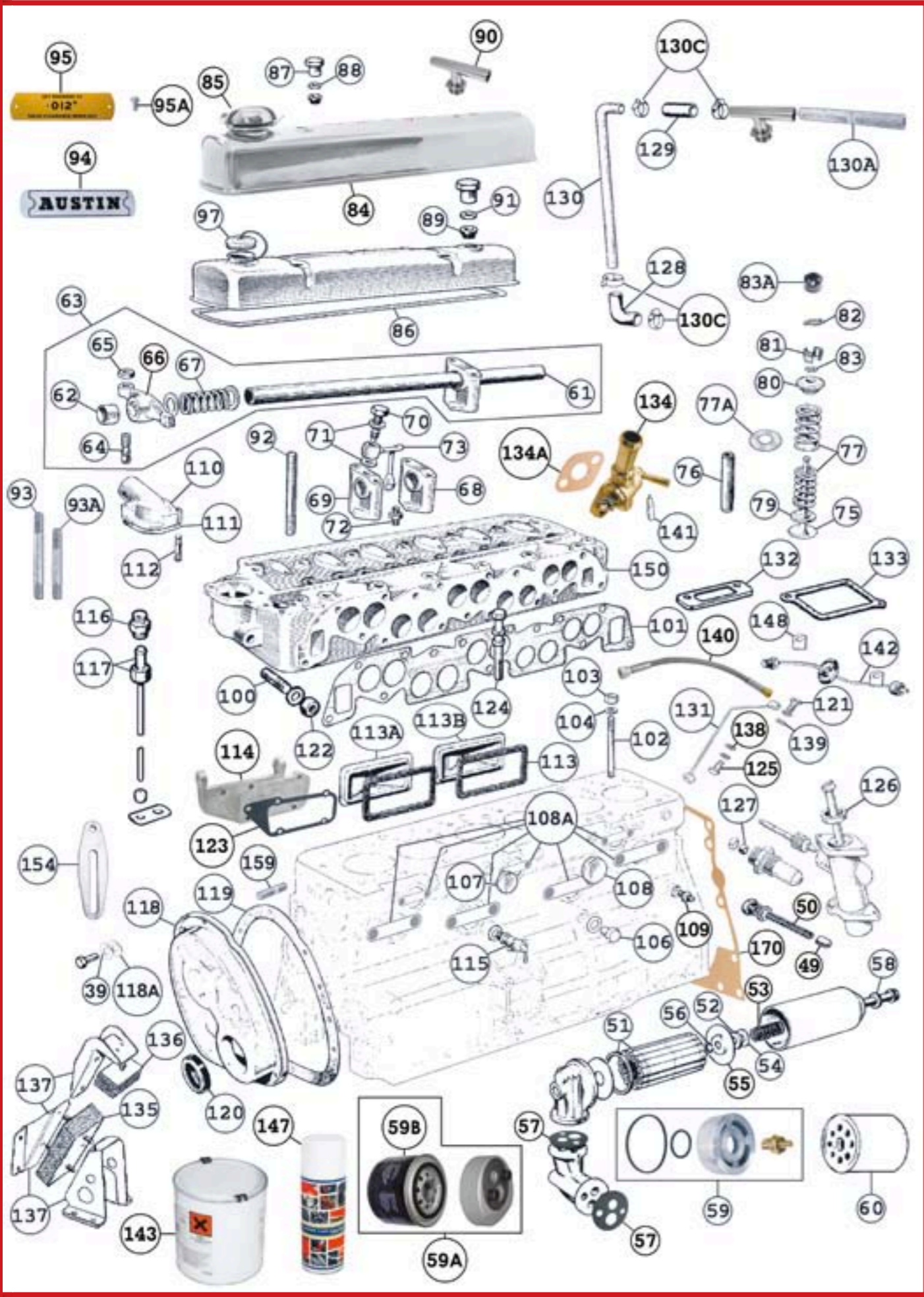

No.	Part No.	Description	Application	Notes	Price ex VAT
49	ENG685	VALVE-oil pressure release	BN4-BJ8		£6.25
50	ENG686	SPRING-oil pressure release	BN4-BJ8		£1.29
51	ENG687	OIL FILTER ELEMENT-felt	BN4-BJ8		£8.50
51	ENG688	OIL FILTER ELEMENT-paper	BN4-BJ8		£3.75
52	ENG690	SEAL-oil filter bowl	BN4-BJ8		£1.62
53	ENG691	SPRING-oil filter	BN4-BJ8		£1.50
54	ENG692	PLAIN WASHER-oil filter bowl	BN4-BJ8		£0.24
52	ENG693	FELT WASHER-oil filter bowl	BN4-BJ8		£0.29
55	ENG694	PLATE-oil filter bowl	BN4-BJ8		£10.50
56	ENG695	CIRCLIP-oil filter bowl	BN4-BJ8		£0.49
57	ENG696	GASKET-oil filter adaptor	BN4-BJ8		£0.45
58	ENG697	SEAL-bolt to filter bowl	BN4-BJ8		£1.75
59	ENG698	ADAPTOR KIT-spin off filter	BN4-BJ8	NOT TECALEMIT	£53.95
59A	ENG698A	KIT-spin off filter	BN4-BJ8	DIRECT TO BLOCK	£35.95
59B	ENG698F	FILTER-spin off type	BN1-BJ8	FOR ENG489 & 698A KITS	£6.95
60	ENG699	CANISTER FILTER-spin off type	BN4-BJ8	FOR ENG698 PURILATOR KIT	£3.25
61	ENG700	ROCKER SHAFT	BN4-BJ8		£21.75
61	ENG700R	ROCKER SHAFT-UPRATED COMP	BN4-BJ8		£89.95
62	ENG701	BUSHES-rocker shaft	BN4-BJ8		£1.90
63	ENG702	ROCKER SHAFT ASSY - reconditioned	BN4-BJ8	EXCHANGE ONLY £200 surcharge	£165.00
64	ENG703	SCREW-rocker adjusting	BN4-BJ8		£6.95
65	ENG704	NUT-rocker adjusting screw	BN4-BJ8		£0.19
66	ENG705	ROCKER ARM - with bush	BN4-BJ8		£13.95
67	ENG706	SPRING-rocker arm spacing	BN4-BJ8		£1.35
68	ENG707	ROCKER PEDESTAL-plain	BN4-BJ8		£11.95
69	ENG708	ROCKER PEDESTAL-tapped hole	BN4-BJ8		£23.50
70	ENG709	BANJO BOLT-oil feed	BN4-BJ8		£4.35
71	ENG710	WASHER-banjo bolt	BN4-BJ8		£0.69
72	ENG711	UNION-rocker oil feed pipe	BN4-BJ8		£2.50
73	ENG712	PIPE-oil feed	BN4-BJ8		£17.50
75	ENG718	VALVE-inlet	BN4	WITH INTEGRAL M/FOLD	£5.95
75	ENG719	VALVE-exhaust	BN4	WITH INTEGRAL M/FOLD	£6.95
75	ENG720	VALVE-inlet	BN4-BJ8		£5.10
75	ENG720C	VALVE-inlet COMPETITION	BN1-BJ8	USE IF UNLEADED	£15.50
75	ENG721	VALVE-exhaust	BN1-BJ8		£7.85
75	ENG721C	VALVE-exhaust COMPETITION	BN1-BJ8	USE IF UNLEADED	£21.50
76	ENG722	GUIDE-inlet valve	BN4-BJ8		£1.75
76	ENG722B	GUIDE-inlet valve-bronze	BN4-BJ8	BRONZE	£5.35
76	ENG723	GUIDE-exhaust valve	BN4-BJ8		£1.95
76	ENG723B	GUIDE-exhaust valve-bronze	BN4-BJ8	BRONZE	£5.95
77	ENG725	VALVE SPRING SET	BN4-BJ8		£19.50
77	ENG726	VALVE SPRING SET - UPRATED	BN4-BJ8	USE.COM274	-
77A	ENG727	SHIM-valve spring .010"	BN1-BJ8	BORE SIZE .595"	£0.69
77A	ENG727A	SHIM-valve spring .015"	BN1-BJ8	BORE SIZE .595"	£0.69
79	ENG730	BOTTOM COLLAR-valve spring	BN4-BJ8		£2.95
80	ENG731	CAP-valve spring	BN4-BJ8		£2.95
80	ENG731C	CAP ALUMINIUM-valve spring	BN1-BJ8	LIGHT WEIGHT	£7.95
80	ENG731S	CAP-LIGHTWEIGHT-valve spring	BN1-BJ8	STEEL	£6.95
81	ENG733	COLLETS-valve(pr.)	BN1-BJ8		£3.55

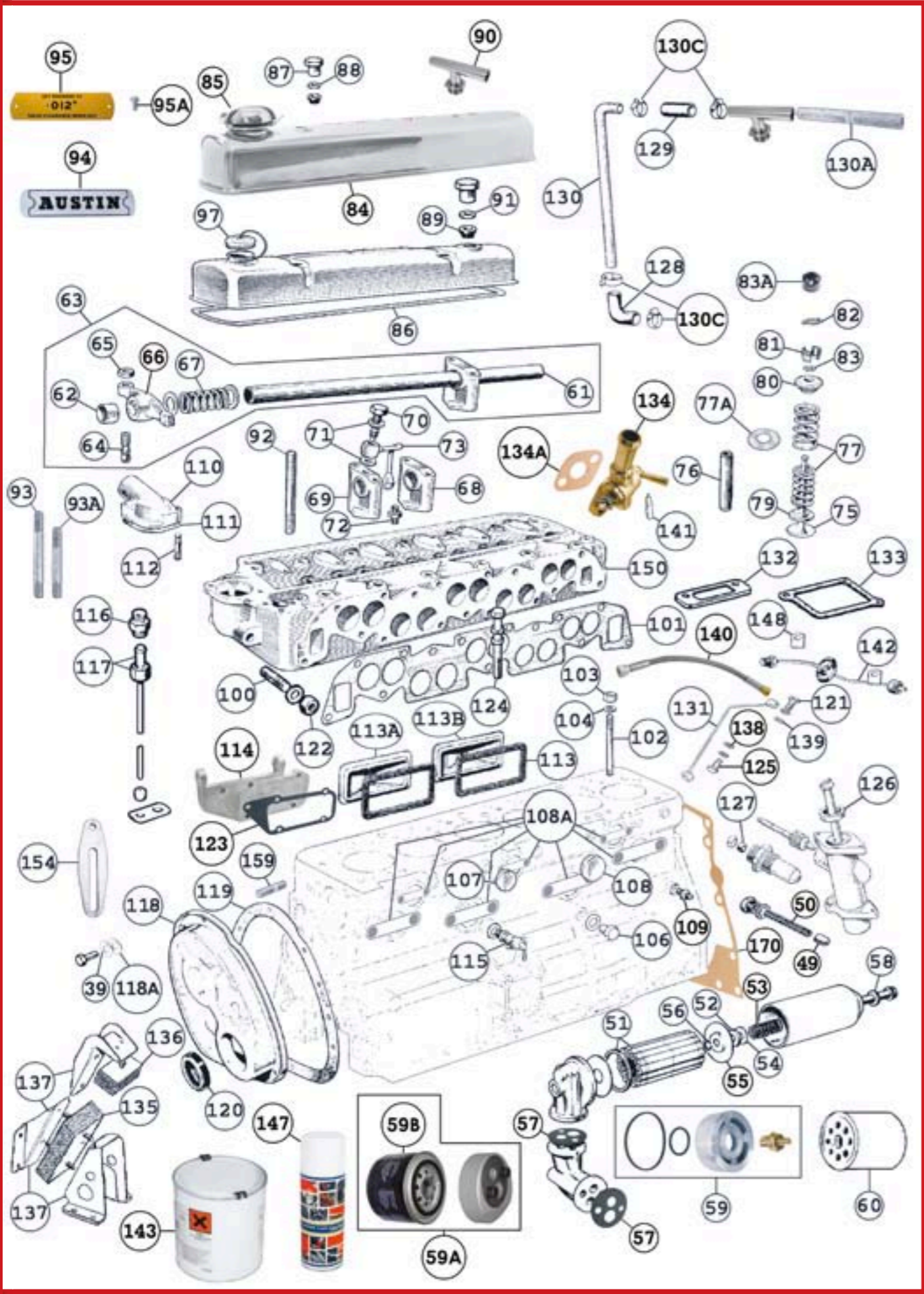

No.	Part No.	Description	Application	Notes	Price ex VAT
82	ENG734	CLIP-valve collets	BN4-BJ8		£0.56
83	ENG735	OIL SEAL-valve stem	BN4-BJ8		£0.10
83A	ENG735C	OIL SEAL-valve stem-modified	BN1-BJ8	DOUBLE SPRING	£1.85
84	ENG736	ROCKER COVER-alloy with QA cap	BN4-BJ8	ENGRAVED	£139.50
84	ENG736C	ROCKER COVER-Engraved	BN4-BJ8	CRACKLE BLACK FINISH	£153.50
84	ENG737	ROCKER COVER-alloy with QA cap	BN4-BJ8	PLAIN	£125.00
85	ENG738	FILLER CAP-quick release	A/R	TO SUIT ENG736	£39.95
86	ENG739	GASKET-rocker cover	BN4-BJ8		£4.25
87	ENG740	CAP NUTS-rocker cover(S.S.)	BN4-BJ8		£9.35
88	ENG741	CAP WASHERS-rocker cover(S.S.)-PR	BN1-BJ8	PAIR	£6.45
89	ENG742	RUBBER BUSH-rocker cover	BN1-BJ8		£0.45
90	ENG743	TPIECE-ROCKER COVER(S.S.)	BN4-BJ8		£31.95
91	ENG744	CUP WASHER-rocker cover-steel	BN4-BJ8		£1.15
92	ENG745	STUD-rocker cover	BN4-BJ8		£1.55
93	ENG746	STUD-rocker pedestal-long	BN4-BJ8		£2.80
93A	ENG747	STUD-rocker pedestal-short	BN4-BJ8		£2.50
94	ENG750	PLATE-AUSTIN(metal)	BN4-BJ8		£3.95
94	ENG751	PLATE-AUSTIN(self adhesive)	LATE BJ8		£3.50
95	ENG752	PLATE '012' (metal)	BN4-BJ8		£4.50
95	ENG752A	PLATE '012' (self adhesive)	LATE BJ8	FITTED TO BJ8 E.29K/10271 ONWARDS	£2.95
95A	ENG753	RIVET - for plates	BN4-BJ8		£0.42
97	ENG755	FILLER CAP-rocker cover	BN4-BJ8		£6.25
100	ENG758	STUD-head to manifold	BN4-BJ8		£1.25
100	ENG758A	STUD LONG - head to manifold	BN4 (2PORT)		£2.75
101	ENG759	GASKET-manifold to head	BN4-BJ8		£4.75
101	ENG759A	MANIFOLD GASKET SET	BN4-2 PORT		£6.25
102	ENG759E	STUD-cylinder head-LONG	BN4-2 PORT		£9.35
102	ENG760	STUD-cylinder head	BN4-BJ8		£3.95
102	ENG760C	HEAVY DUTY CYLINDER HEAD STUDS	BN4-BJ8	WAISTED-COMPETITION	£5.95
103	ENG761	NUT-cylinder head	BN4-BJ8		£1.45
103	ENG761C	HEAVY DUTY NUT-cylinder head-ARP	BN4-BJ8	ARP FLANGE TYPE	£1.55
104	ENG762	WASHER-head stud	BN4-BJ8		£0.12
104	ENG762C	WASHER-head stud H/DUTY	BN1-BJ8	COMPETITION	£0.95
106	ENG764	PLUG-oil filter feed hole	BN4-BJ8		£7.50
107	ENG765	CORE PLUG-small,saucer type	BN4-BN6		£0.55
107	ENG766	CORE PLUG-small,cup type	BT7-BJ8		£0.85
108	ENG767	CORE PLUG-large,saucer type	BN4-BN6		£0.69
108	ENG768	CORE PLUG-large,cup type	BT7-BJ8		£0.95
108A	ENG768S	STRAP KIT-core plugs	BN4-BJ8	INC SCREWS	£20.95
109	ENG769	UNION-oil gauge pipe	BN4-BJ8		£8.95
109	ENG769W	WASHER - UNION-oil gauge pipe	BN4-BJ8		£0.99
	ENG770	THERMOSTAT	BN4-BJ8	USE.CHT119	-
110	ENG771	HOUSING-thermostat	BN4-BJ8	USE.CHT120	-
111	ENG772	GASKET-housing	BN4-BJ8	USE.CHT121	-
112	ENG773	STUD-thermostat housing	BN4-BJ8		£0.69
113	ENG774	GASKET-rear tappet cover	BN4-BJ8		£1.25
113A	ENG774A	TAPPET COVER CENTRE	BN4-BJ8	USE.COM277	-
113B	ENG774B	TAPPET COVER REAR	BN4-BJ8	USE.COM278	-
114	ENG775	DYNAMO BRACKET/TAPPET COVER	BN4-BJ7		£75.00
114	ENG776	DYNAMO BRACKET/TAPPET COVER	BJ8		£75.00

ENGINE - 6 CYLINDER - 2

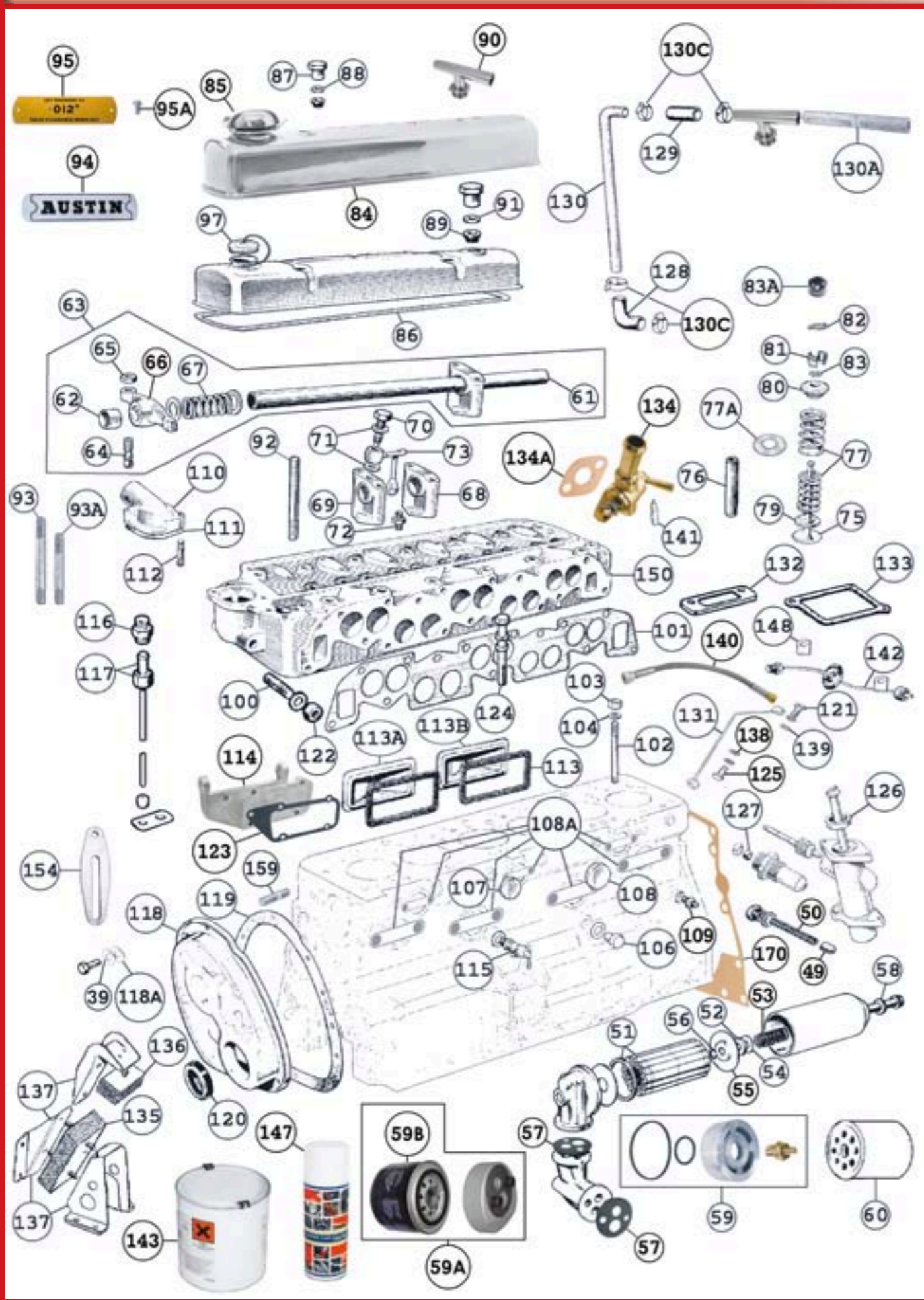

No.	Part No.	Description	Application	Notes	Price ex VAT
115	ENG777	DRAIN TAP-cylinder block	BN4-BJ8		£26.95
116	ENG778	BRASS UNION-manifold drainpipe	BN6-BJ8	NOT TRI-CARB	£2.45
117	ENG779	DRAIN TUBE & NUT-manifold	BN6-BJ8	NOT TRI-CARB	£8.25
118	ENG780C	INSPECTION FRONT COVER-EXCHANGE	BN4-BJ8	EXCHANGE ONLY	£142.50
118A	ENG780W	WASHER-timing chain cover	BN4-BJ8		£0.55
119	ENG781	GASKET-timing cover	BN4-BJ8		£1.25
120	ENG782	OIL SEAL-timing cover	BN4-BJ8		£2.95
121	ENG783	BANJO BOLT-oil feed tacho	BN4-BJ7	TACHO END	£8.50
122	ENG784	BRASS NUT-manifold to head	BN4-BJ8		£1.05
123	ENG785	GASKET-dynamo bracket	BN4-BJ8		£0.65
124	ENG786	BOLT-inlet to exhaust manifold	BT7-BJ8		£0.95
125	ENG787	BANJO BOLT-oil feed tacho	BN4-BJ7	CRANK END	£6.95
126	ENG788	OIL SEAL-distributor drive	BN4-BJ8		£2.10
127	ENG789	OIL SEAL-tacho drive	BN1-BJ7		£3.25
128	ENG790	RUBBER ELBOW-breather pipe	BN4-BJ8		£3.95
129	ENG791	RUBBER,STRAIGHT-breather pipe	BN4-BJ8		£1.20
130	ENG791S	BREATHER PIPE - S.STEEL	BN4-BJ8	POLISHED	£15.45
130	ENG792	BREATHER PIPE	BN4-BJ8		£10.75
130A	ENG792A	BREATHER HOSE-filter to cover	BN4-BJ8		£5.75
130C	ENG792C	CLIP-breather hose	BN4-BJ8	USE.CHT181A	-
130F	ENG792F	CRANK CASE BREATHER FILTER	BN1-BJ8	PIPERCROSS-SILVER	£20.95
131	ENG793	PIPE ASSY - oil feed	BN4-BJ7		£31.95
132	ENG794	GASKET-HOT SPOT-inlet to exh.	BN7&BT7	TRI-CARB ONLY	£1.20
133	ENG795	GASKET-inlet to exh. manifold	BN4-BJ8		£1.48
134	ENG798	TAP-HEATER CONTROL-cyl. head	BN4-BJ8		£46.50
134A	ENG798A	GASKET -TAP HEATER CONTROL-cyl. head	BN4-BJ8		£0.26
135	ENG800	ENGINE MOUNTING	BN4-BJ8		£9.15
136	ENG801	REBOUND-engine mounting	BN4-BJ8		£4.25
137	ENG802	BRACKET SET-R/H-engine mounting uprated	BN4-BJ8		£79.50
137	ENG802A	BRACKET SET-L/H-engine mounting uprated	BN4-BJ8		£79.50
138	ENG803	WASHERS-pr-banjo bolt	BN4-BJ7		£1.15
139	ENG804	WASHER-banjo bolt	BN4-BJ7	USE.ENG710	-
140	ENG805	FLEXIBLE PIPE-oil pressure	BN4-BJ8		£11.85
141	ENG806	BRASS LEVER-heater tap	BN4-BJ8		£5.50
142	ENG807	PIPE-oil pressure-to gauge-RHD	BN4-BJ7	R.H.D	£16.50
142	ENG808	PIPE-oil pressure-to gauge-RHD	BJ8	R.H.D	£16.50
142	ENG809	PIPE-oil pressure-to gauge-LHD	BN4-BJ8	L.H.D	£16.50
143	ENG810	ENGINE PAINT-(1.litre tin)	BN4-BJ8		£15.95
147	ENG815	AEROSOL ENGINE PAINT	A/R	POST TO UK ONLY	£10.75
148	ENG816	CLIP - oil pipe	BN4-BJ8		£0.68
150	ENG820	CYL HEAD-recon-unleaded-exchge	BN4-BJ8	INC VALVES ETC £500 surcharge	£765.00
150	ENG820A	CYL HEAD-recon-unleaded-OUTRIGHT SALE	BN4-BJ8	INC VALVES ETC	£995.50
150	ENG821	CYL HEAD-aluminium-c/w valves	BN4-BJ8		£2,395.00
154	ENG825	ADJUSTING STRAP - dynamo	BN4-BJ8		£10.50
159	ENG830	STUD-Water pump	BN4-BJ8		£1.19
164	ENG835	PLUG - oil gallery	BN1-BJ8		£4.50
170	ENG840	GASKET - BACK PLATE	BN4-BJ8		£3.50