

Austin Healey BN2 - BN6

BRK100B4P - Aluminium 4-Pot Front Disc Brake Conversion Kit

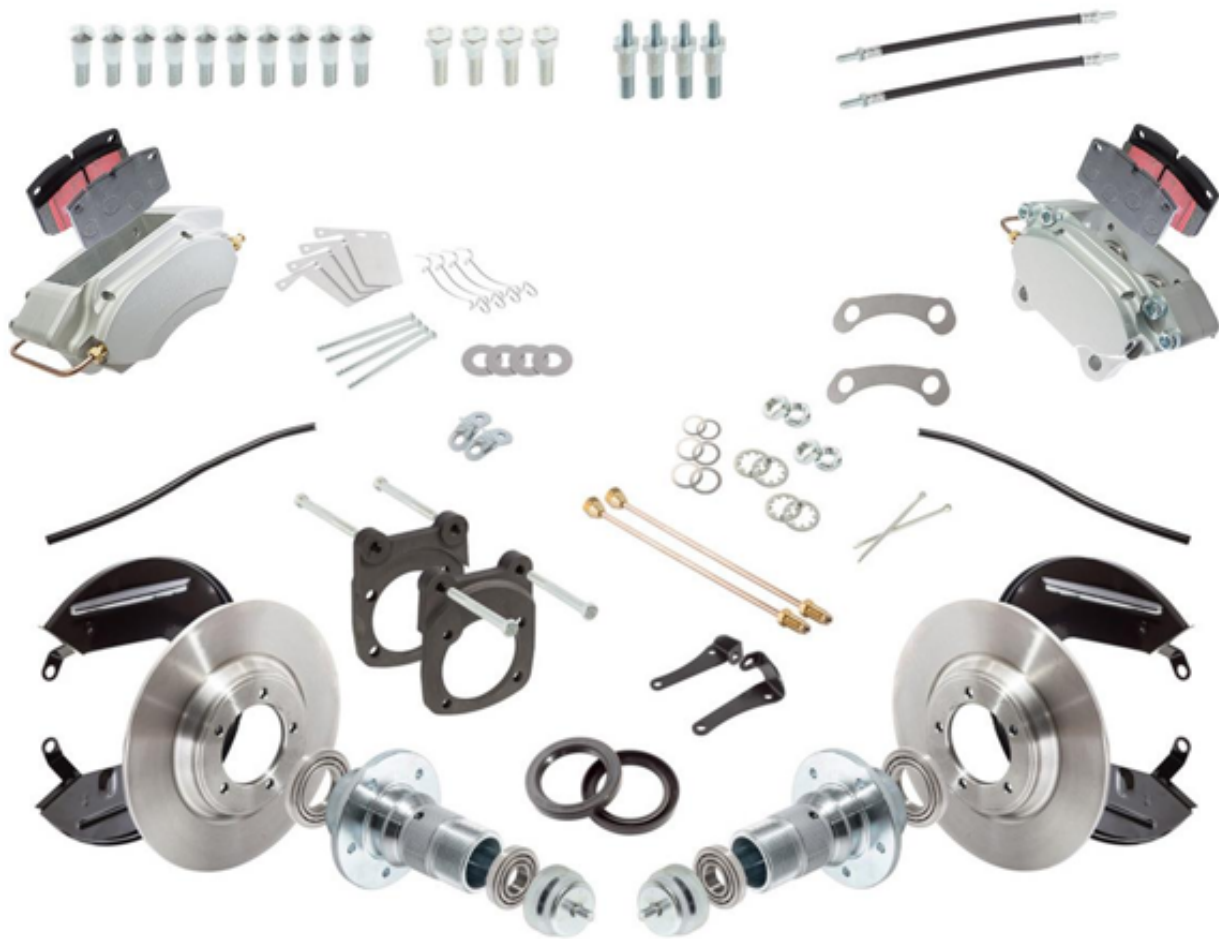

Thank you for buying this CapeSport product, which has been designed to enhance the enjoyment of your Austin Healey.

PLEASE READ THESE INSTRUCTIONS BEFORE YOU COMMENCE THE INSTALLATION OF THIS PRODUCT.

IN THE INTERESTS OF HEALTH AND SAFETY IF YOU HAVE ANY RESERVATIONS CONCERNING THE EQUIPMENT OR EXPERTISE REQUIRED TO INSTALL THIS PRODUCT PLEASE CONSULT A QUALIFIED CLASSIC CAR SPECIALIST.

General Installation Steps

Read the fitting instructions prior to starting any work, if you are unsure that you have the correct tools or mechanical experience then please contact a specialist or a qualified mechanic to install the conversion kit for you, **THIS IS A SAFETY CRITICAL** system of the vehicle so needs to be fitted correctly for the safety of both the users of the vehicle and other road users

Gather Tools:

- » PVC gloves (brake fluid is harmful to humans)
- » Face mask (brake dust is harmful if inhaled)
- » Release spray-WD40 or equivalent (for those stubborn or frozen fasteners)
- » High quality high temperature grease
- » Brake cleaner spray
- » Degreaser/parts cleaner fluid/spray
- » Plenty of Cloths
- » Small drip tray (to catch brake cleaner run off)
- » Unopened DOT3/4 brake fluid- 1 litre bottle to make sure you have enough
- » Hub puller
- » Tie rod/track rod end separator
- » Bearing drifts
- » Torque wrench
- » Imperial/AF spanners
- » Brake pipe spanner
- » Imperial/AF socket set
- » Impact screwdriver
- » Screwdrivers (blade type & pozi-drive & Philips)
- » Needle nose pliers
- » Brake pipe bender
- » Pressure bleeder or willing helper for refilling system with new fluid

Kit Contents:

Part number	Description	Qty in kit
BRK151	Brake disc	2
BRK400	4 Pot Brake caliper set	1
BRK164	Brake pad set	1
BRK172	RH dust shield	1
BRK173	LH dust shield	1
BRK174	Rubber seal for dust shields	2
BRK180	Caliper mounting brackets (Pair)	1
BRK182S	Caliper shims	4
BRK183	RH bracket for caliper metal brake pipe	1
BRK184	LH bracket for caliper metal brake pipe	1
BRK191	Flexi brake hose	2
BRK209	Flexi brake hose bracket to chassis	2
FAS5184	3/8" jam/half nut	4
FAS5414	3./8" locking nut for brake disc	10
FAS7256	5/16" spring washer	4
FAS7258	3./8" spring washer	14
FAS7260	7/16" spring washer	4
FAS7458	3/8" shakeproof washer (internal teeth)	4
SUF167	Stud hub to disc	10
SUF134	Lock/tab washer steering arm bolts	2
SUF137	Bolt dust shield to swivel axle	4
SUF142	Oil seal front hub	2
SUF144	Inner wheel bearing	2
SUF148	Outer wheel bearing	2
SUF151	Wheel bearing shim 0.003"	2
SUF152	Wheel bearing shim 0.005"	2
SUF153	Wheel bearing shim 0.010"	2
SUF170	Grease cap	2
SUF184	RH hub	1
SUF185	LH hub	1
SUR147	Split pin for hub nut	2

Preparation:

Secure the vehicle: Safely lift and support the car on jack stands and chock the rear wheels, refer to owners' or workshop manual for correct jacking of vehicle to avoid damage to chassis/body components and avoiding injury.

Front Disc Brake Conversion Steps:

Step 1: Support suspension: Place a piece of 2.5cm thick wood between the shock absorber arm bump rubber and chassis and support the lower wishbone, this will enable safe removal and refitting of components associated with the steering and suspension.

Step 2: Drain the brake system: Drain the old brake fluid via a bleed nipple on one of the front wheel cylinders.

Step 3: Remove old drum brakes:

- » Remove the wheel.
- » Back-off the brake adjusters located on the rear of the brake plate to enable the easy removal of the brake drum.
- » Remove grub screw(s) on drum, remove brake drum.
- » Use brake cleaner to wash off the brake dust from the brake components.
- » Remove the original rubber flexi brake hose from the metal brake pipe junction under the wheel arch.
- » Remove grease cap from the hub using grease cap removal tool.
- » Wipe excess grease from around hub nut to access and remove the split pin.
- » Remove the large retaining nut and withdraw the hub off the spindle using a hub puller.
- » Once the hub is removed from the spindle access will be gained to the 4 bolts that attach the brake plate assembly to the swivel axle, the bottom bolts retain the steering arm that has nuts on the opposite end of the bolts, the top bolts thread direct into the stub axle remove the brake plate complete with the wheel cylinders and brake shoes still attached.

Step 4:

Once the old hub is removed then the bearing spacer will be required to use in the build-up of the new hubs, to remove the bearing spacer remove the outer bearing from the hub following the procedure as defined in the workshop manual, once the outer bearing is removed then the bearing spacer can be retrieved.

Step 5: Install ancillaries onto stub axle

Take the brake caliper brackets from the packet marked BRK180. These are handed, there are 4 bolts in the BRK180 kit:

- » 2 short ones (7/16" x 3.5")
- » 2 long (7/16" x 3.75")

One of each is required to use as new bolts to replace the bottom bolts that were removed from the axle that retain the steering arm.

The lock washer fits under the head of these bolts prior to passing through the stub axle. The brake dust shield has a rubber seal that goes around the inner edge before it is installed. **See Fig 2.** This dust shield is installed during the fitting of the brake caliper bracket. **See Fig 1** showing fitting procedure.

Initially do all fasteners finger tight only. Refit the steering arm to the back of the stub axle along with the spring washers and nuts and initially only tighten finger tight.

Once the 4 bolts that retain the caliper bracket and the dust shield are attached then proceed to fully tighten the fasteners and bend over the lock tabs under the lower bolts heads prior to installing the hub assembly otherwise the heads of the bolts will be obscured by the hub and disc assembly.

Fig. 1:

RH caliper bracket placed on face of RH stub axle.



Top view of caliper bracket on stub axle



Fig. 2:

RH dust shield and fixing bolts loosely fitted

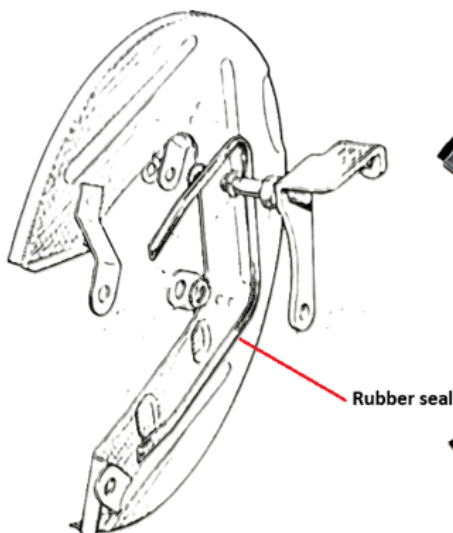

Rear view of RH dust shield loosely installed



Step 6: Build hubs

Unpack hubs and wheel bearing kits and using bearing spacers that were removed from the original hubs plus the new hub nut and tab washer.

Lay out both hubs and the 10 black coloured disc bolts, wheel bearing kits, 4 bearing shims, 2 spacers, 2 hub nuts, 2-tab washers and 2 grease caps.

The studs will require pressing into the hubs prior to fitting the wheel bearings, the studs are installed with the threaded part protruding from the back of the flange, the holes in the hub for the studs are chamfered that matches the chamfer on the underside of the head on the studs.



Correct wheel bearing fitting:

It is important the wheel bearings are fitted to the hub correctly to prevent premature wear or failure of the wheel bearings during service; this kit utilises the later taper bearings and shim pre-load set-up.

See below wheel bearing fit procedure:

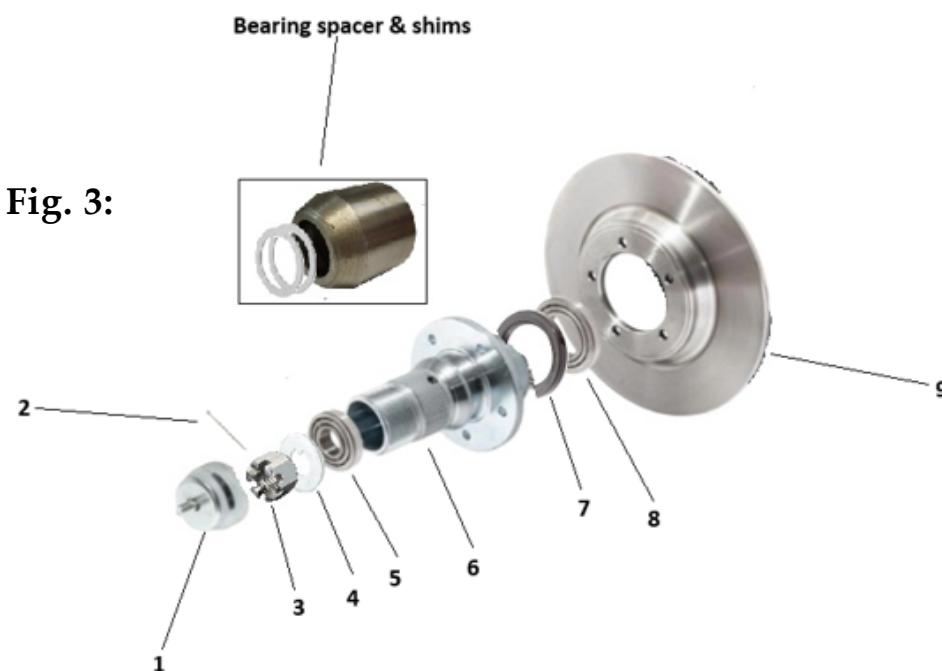

Fig 3 index:

1. Grease cap
2. Split pin
3. Hub nut
4. Tab washer
5. Outer bearing
6. Hub
7. Oil seal
8. Inner bearing
9. Brake disc

Wheel bearing install procedure:

The end float of the bearings must be checked and adjusted when servicing or installing new bearings. The end float is adjustable by means of shims between the inside face of the outer bearing and the nose of the bearing spacer.

1. First install the outer race of the larger inner bearing to the hub, using wheel bearing grease apply a smear of grease on the outer race you have just installed and then apply plenty of grease to the matching roller bearing, it is best to do this whilst wearing disposable gloves so that you can squeeze plenty of grease through the rollers of the bearing, once greased insert the roller bearing part into the race and then fit the oil seal and pack the cavity between the bearing and the oil seal with grease.
2. Flip the hub over and pack the cavity where the bearing spacer sits and install the bearing spacer with the widest end towards the larger inner bearing, next install the smaller outer bearing components using the same procedure as for the larger inner bearing assembly, install the roller part of the outer bearing without any of the shims at this stage.
3. Slid the hub onto the axle spindle and insert the new tab washer and hub nut, tighten the nut whilst rotating the hub back and forth until there is noticeable drag, this ensures that the cones are properly seated.
4. Unscrew and remove the hub nut, extract the washer and the centre of the outer bearing. Insert a sufficient thickness of shim(s) to produce an excessive amount of end-float.
5. Note the total thickness of shims used, replace the bearing centre, washer and nut, tighten the nut.
6. Measure accurately the total amount of end float in the bearings. Remove the hub nut, washer and bearing centre, reduce the number of shims to eliminate end-float whilst still allowing the hub to rotate freely, once this has been achieved refit the centre bearing, washer and hub nut and tighten nut to 40lb/ft-70lb/ft (5.53 to 9.68 kg. m) whilst making sure the that the nut is in the correct position to allow fitting of the split pin and then bend over the ends of the split pin.
7. Remove any surplus grease to allow for expansion and fit the grease cap, **do not pack the grease cap with grease.**

Step 7: Install brake disc

Remove the hub from the stub axle to allow the installation of the brake disc, the brake disc is held on by the studs that protrude from the back of the hub flange and the stiff nuts and 3/8" spring washers supplied in the kit, there are no published torque tightening figures for the nuts.

Fig. 4:

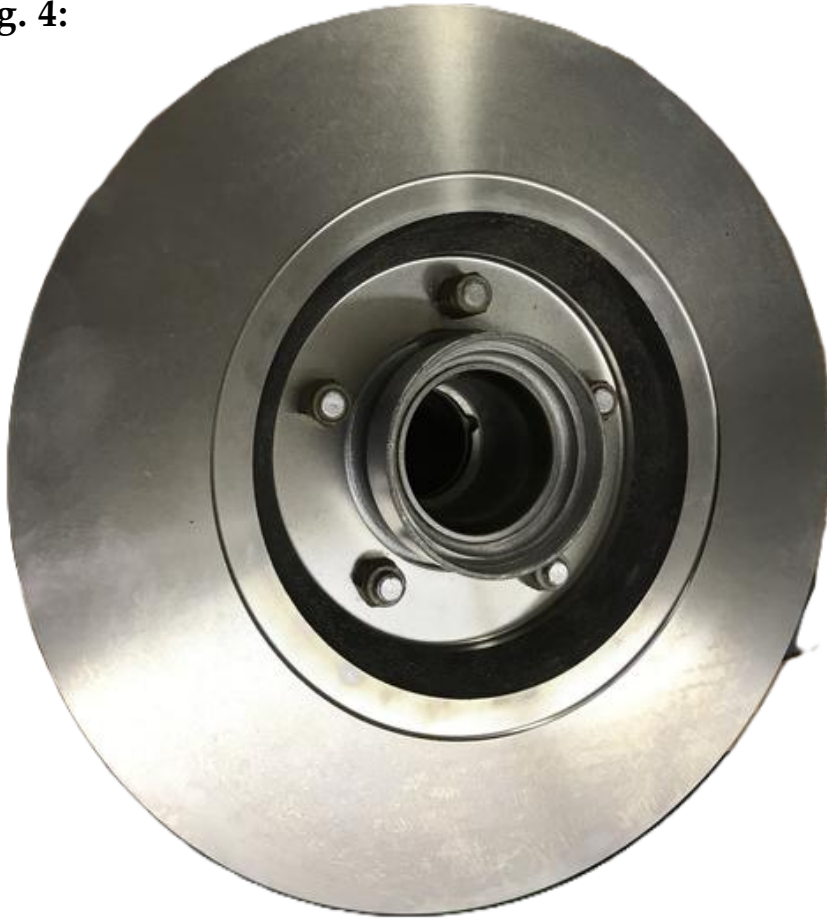

Once the brake disc has been fitted to the hub then refit the hub along with the washer and hub nut and tighten as described in previous section - **refit washer and hub nut and tighten nut to 40lb/ft-70lb/ft (5.53 to 9.68 kg. m) whilst making sure the that the nut is in the correct position to allow fitting of the split pin and then bend over the ends of the split pin.**

Install brake caliper and fittings:

Unpack the brake calipers from their box, the box also contains the 4 caliper mounting bolts and a pair of copper brake pipes.

Install the caliper between the L-shaped brackets on the back of the dust shield and the caliper bracket, and use the double threaded bolts to fix the caliper, do the bolts finger tight at this stage see below image:

Fig. 5:

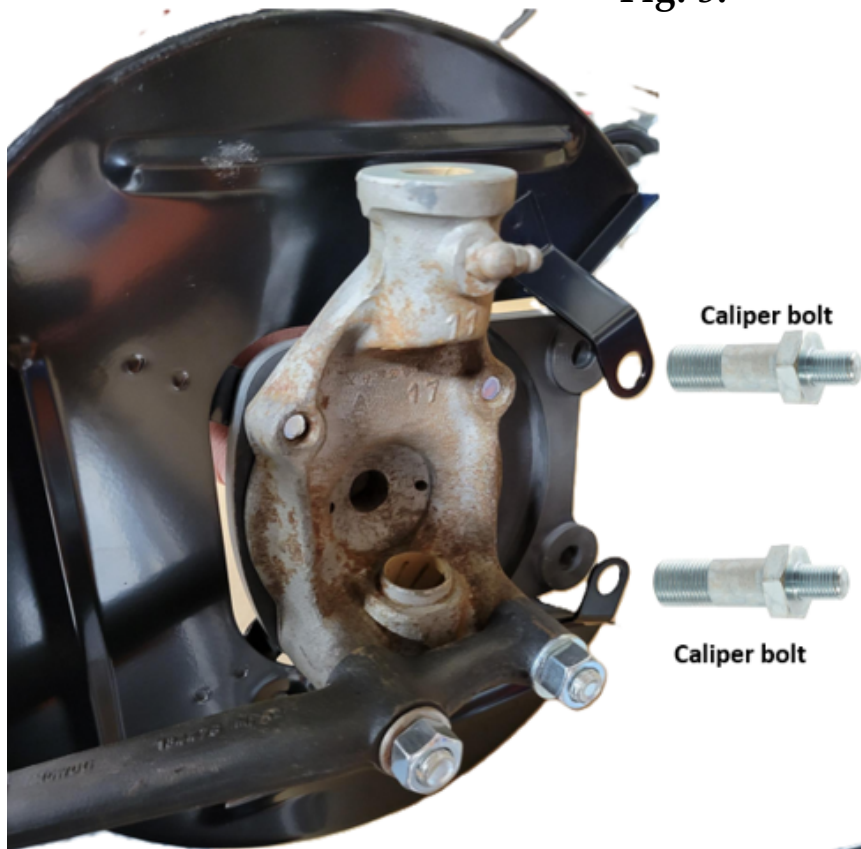
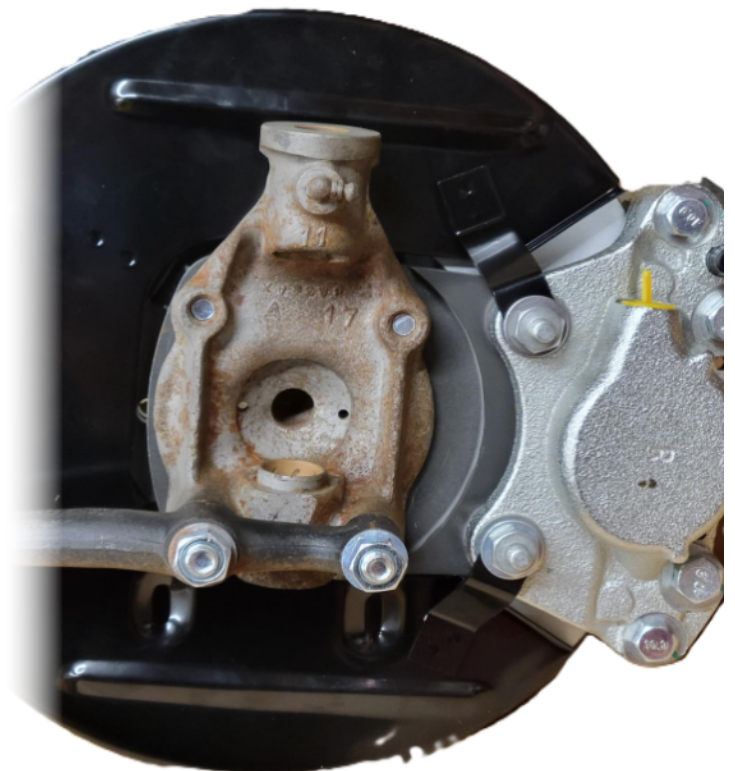

Fig. 6:



Caliper and fittings install:

With the caliper installed check to make sure the brake disc runs central in the caliper, if it does not then remove the caliper bolts and insert one of the supplied shims between the caliper mounting bracket and each caliper mounting lug to centralise the caliper, see Fig 7 and refit the caliper bolts and fully tighten and then install the brake pads.

Fig. 7:

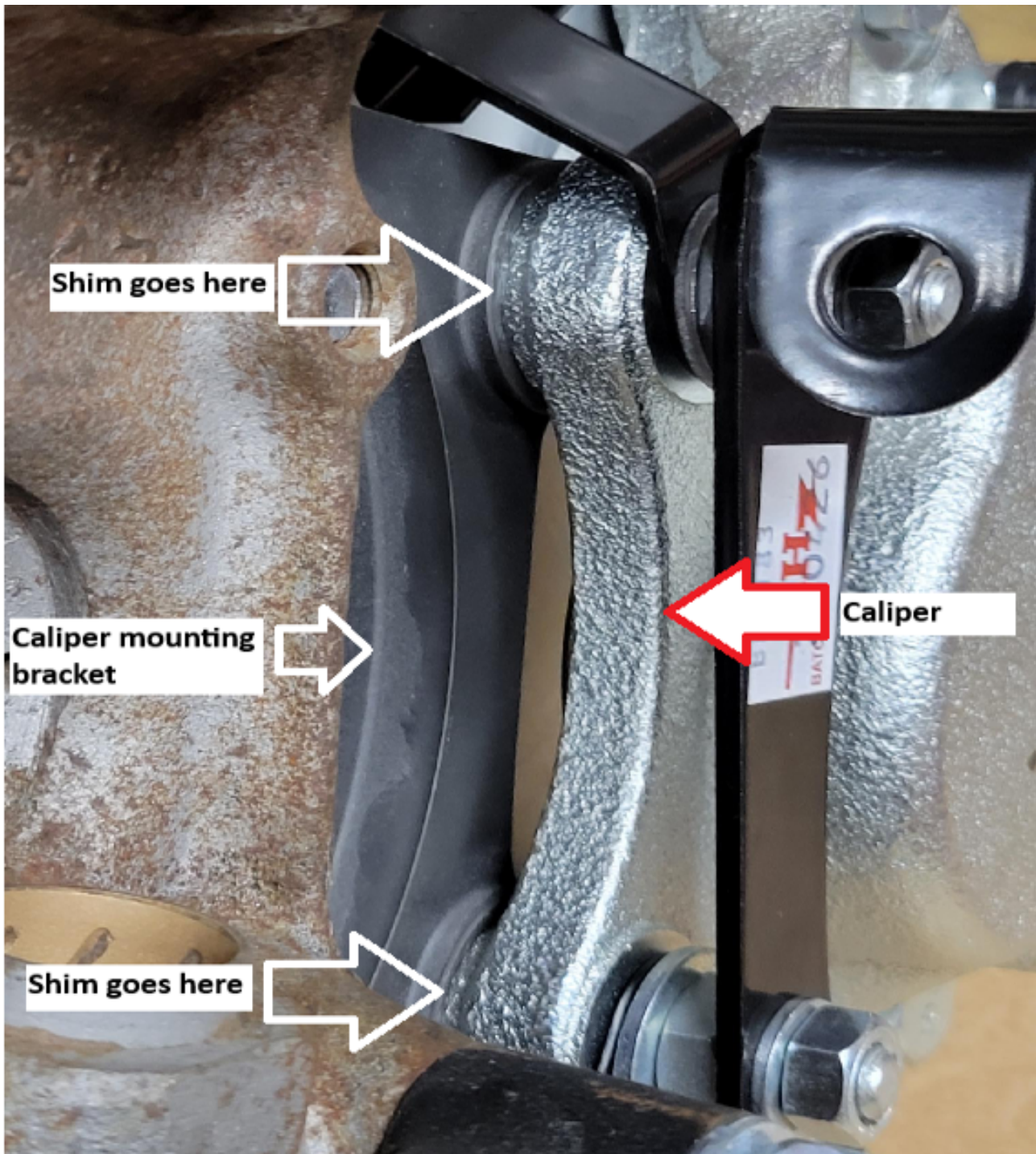

Caliper ancillary installation:

With the brake caliper fully installed and the bolts are fully tightened then proceed to fit the brake hose bracket to the brake caliper bolts, see **Fig 8**:

Fig. 8:



Fitting brake hose and pipe:

There is a bracket supplied in the kit labelled BRK209 which attaches to the gusset on the side of the shock absorber platform, see item 51 on Fig 9

Fig. 9:

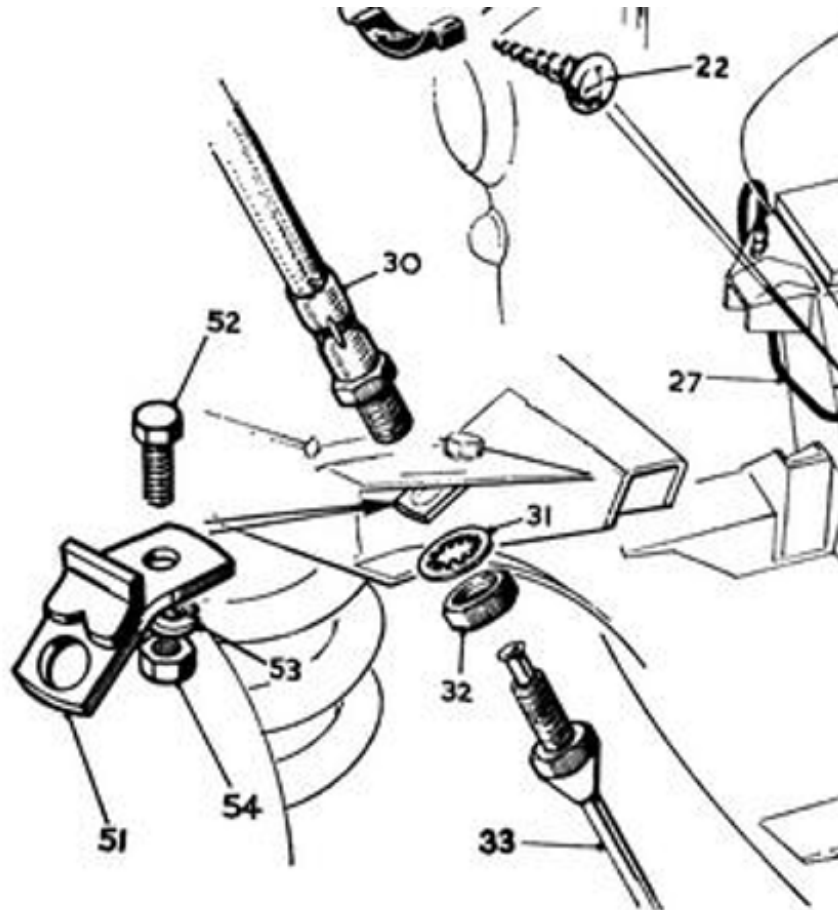

Fig 9 index applicable to kit:

Item 51 brake hose bracket

Item 30 flexi brake hose

Item 31 3/8" shake proof washer

Item 32 3/8" half nut (locknut)

Fig. 10:



Once bracket is fitted, the flexi hose fits through the top of the gusset and through the hole in the bracket then secured to the bracket with the shakeproof washer and the half nut (locknut). Only do the nut finger tight at this stage.

The copper brake pipe still on the car is then threaded onto the end of the flexi hose. Using an open-end wrench hold the flexi hose on its hexagon section and using another open end wrench tighten fully the copper pipe onto the flexi hose-**make sure the flexi hose does not twist**, then fully tighten the half nut (locknut).

The opposite end of the flexi hose is then fitted to the brake hose bracket on the caliper, see **Fig 11**. The threaded part of the hose is passed through the hole and one of the 3/8" shakeproof star washers is fitted, then one of the other half nuts (locknut). Initially tighten finger tight only. Take one of the copper brake pipes and using a pipe bender, form the pipe to the shape shown in **Fig 12 and Fig 13**.

Once the pipe has been formed and carefully threaded first into the caliper and then onto the end of the flexi hose- you may need to manipulate the copper pipe to get it to thread straight- be careful not to cross-thread either end- once the copper pipe is fitted and finger tight proceed to fully tighten both ends of the copper pipe into the caliper and onto the flexi hose and then fully tighten the half nut (locknut) holding the flexi hose to the hose bracket.

Fig. 11:

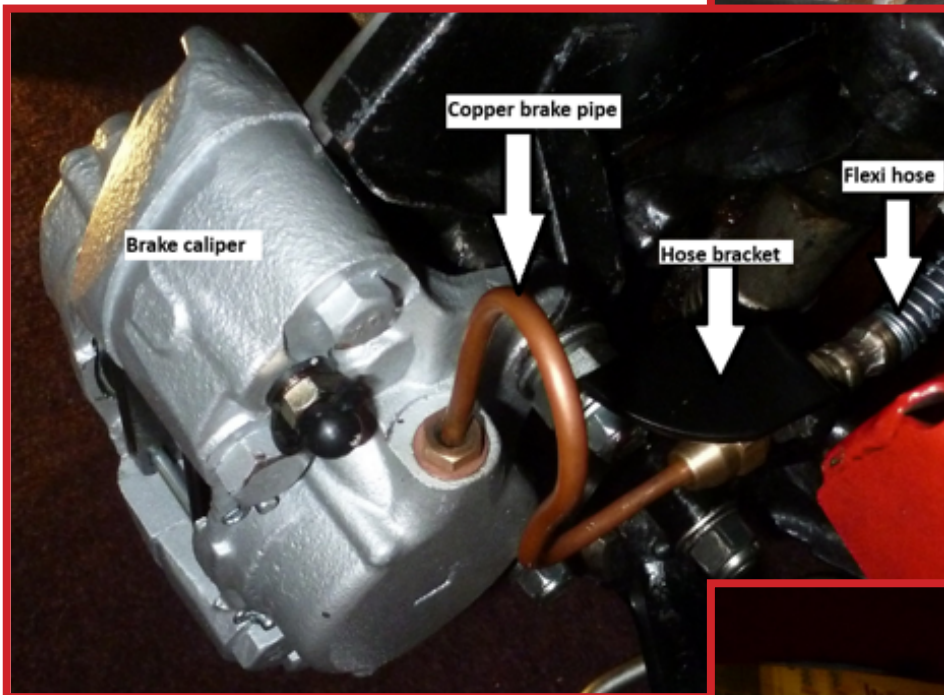
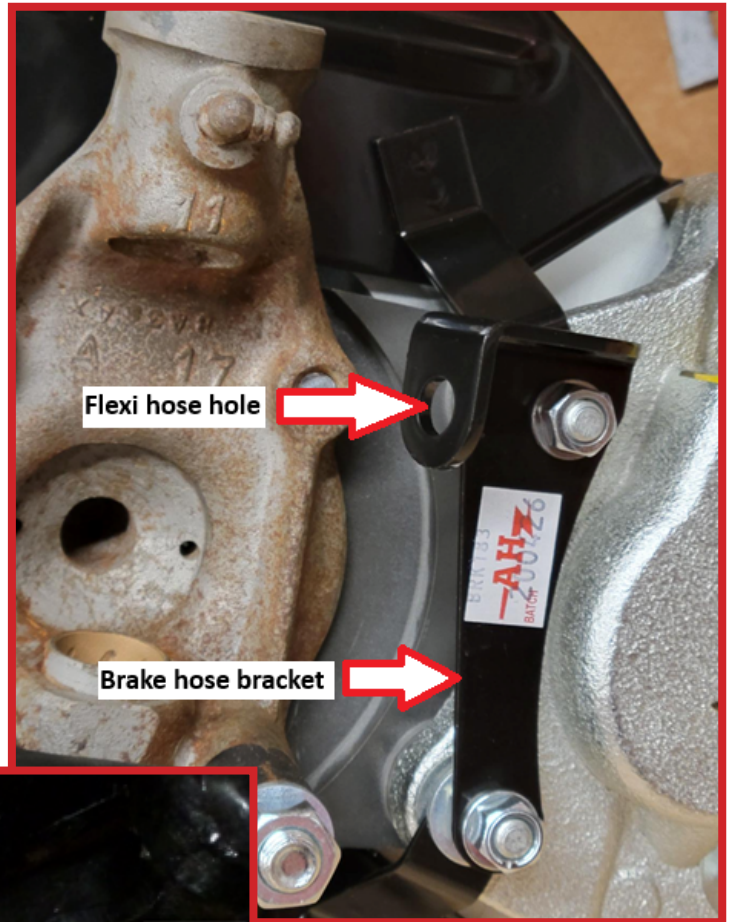
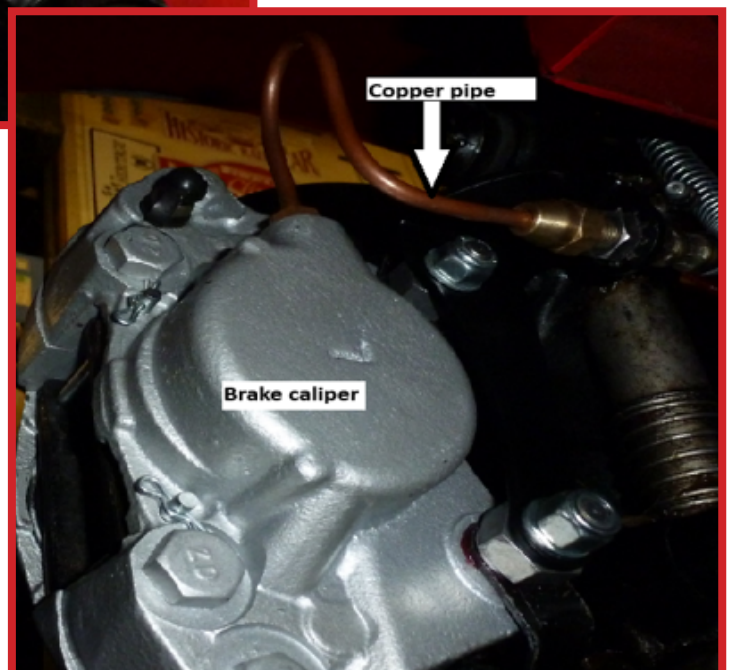

Fig. 12:
View from top of caliper

Fig. 13:
View from underside of caliper



Final checks and procedures:

Repeat the above procedure for the opposite side of the car, once the opposite side is complete proceed with final checks and procedures.

Final checks:

Check all the fasteners are fully tightened, make sure the fasteners with factory torque settings are tightened to correct torque settings where applicable.

Check that there are no parts that are fouling/rubbing against other components-**pay special attention to the flexi hoses.**

Once all the above have been completed proceed to filling the brake reservoir with fresh brake fluid and proceed to bleed the brake system using the workshop manual bleeding sequence.

Once the system has been bled then check for any leaks, proceed to refitting the front wheels and fully tighten the spinners.

As some of the steering system has been removed and refitted it is good practice to check the tracking and toe-in/toe-out, see **Fig 14.**

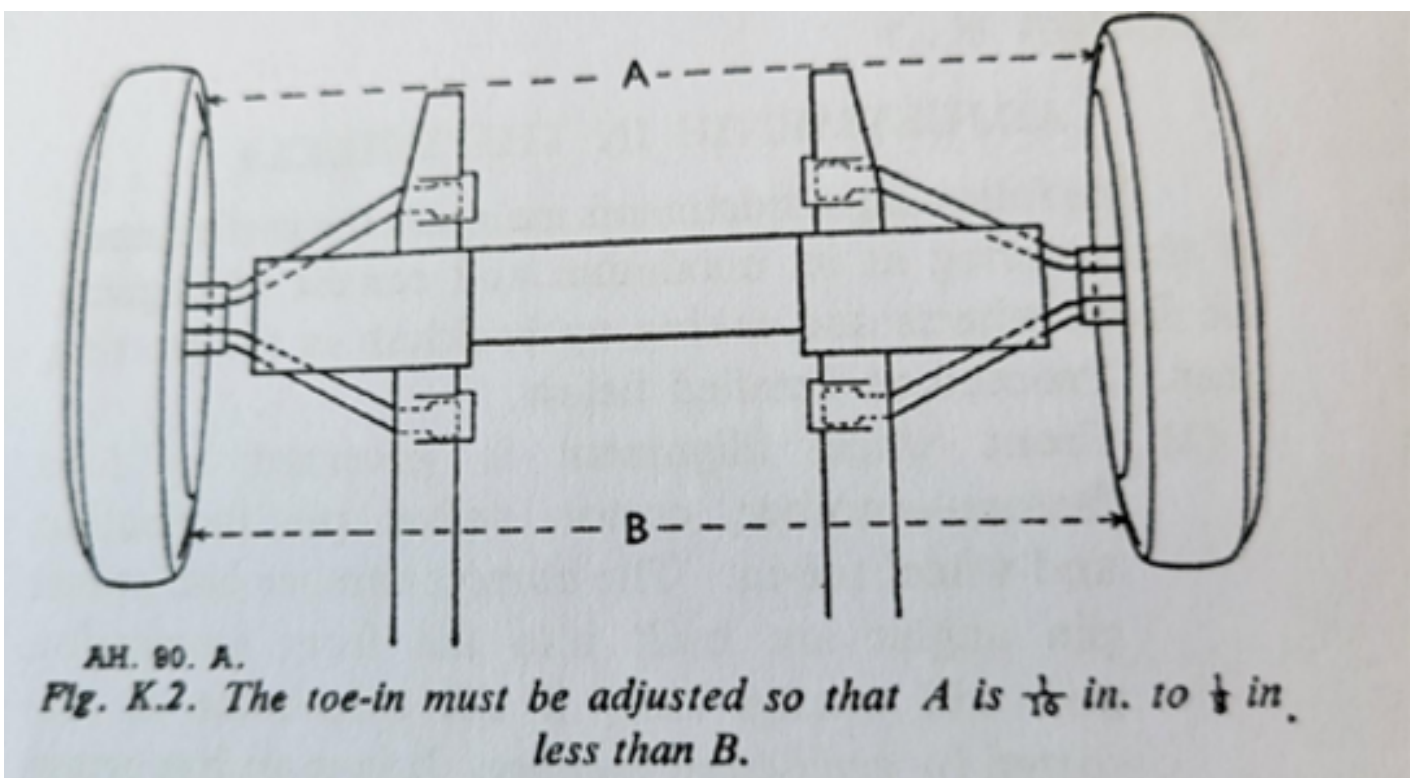

Take the vehicle for a steady road test and apply the brakes steadily and safely-gradually increasing brake pressure and return to workshop and double check for leaks and bolt tightness.

When ready for a longer road test avoid heavy sharp braking for the first 100-150 miles to bed-in the pads.