

EXHAUST SYSTEMS

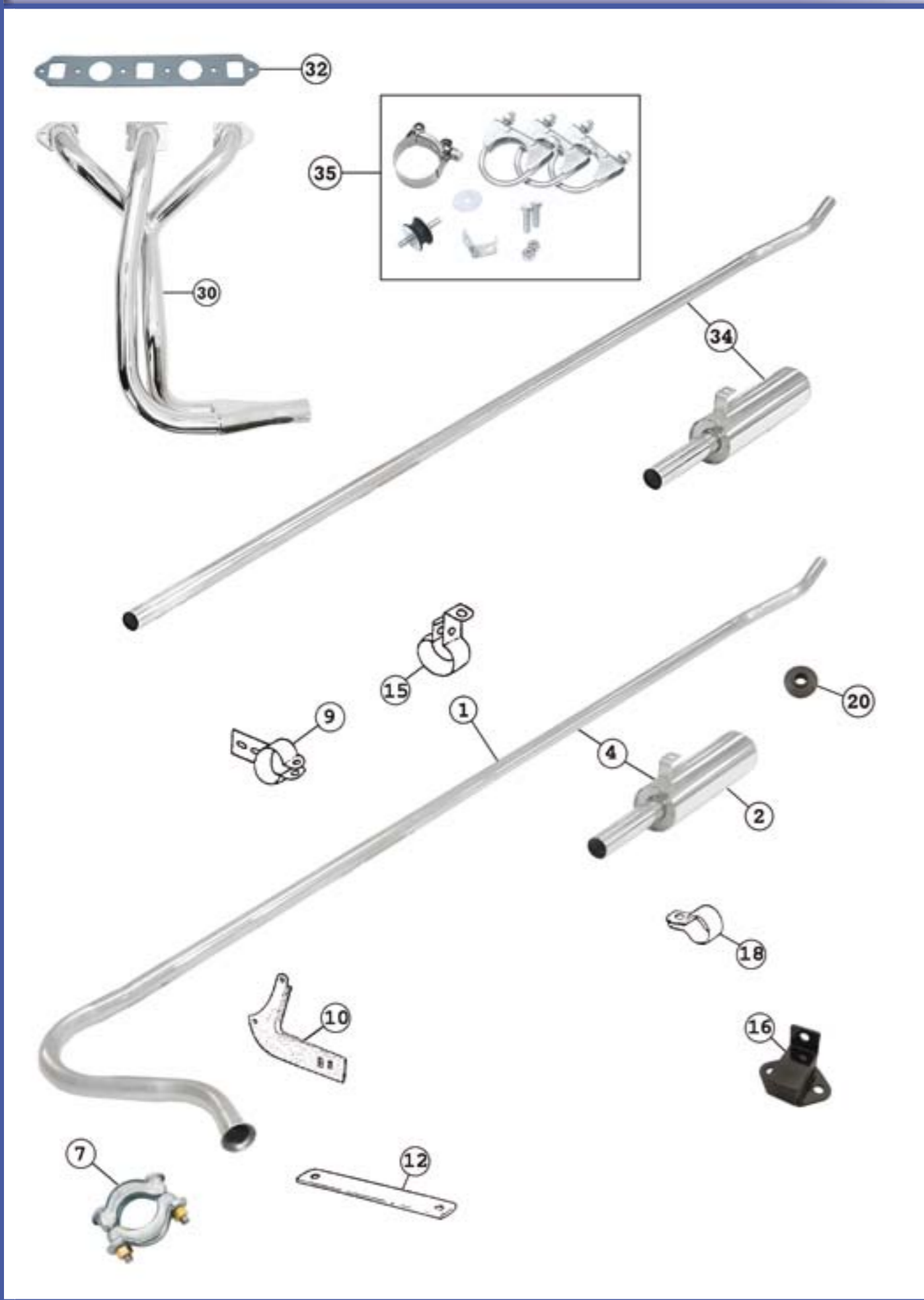

No.	Part No.	Description	Application	Notes	Price ex VAT
1	XEXS101	FRONT PIPE	MK1-MK2		£37.50
1	XEXS102	FRONT PIPE	MK3-MK4		£26.50
2	XEXS103	SILENCER	MK1-MK2		£26.50
2	XEXS104	SILENCER	MK3-MK4		£29.95
4	XEXS106	EXHAUST SYSTEM-STAINLESS STEEL	MK1-MK2		£103.95
4	XEXS107	EXHAUST SYSTEM-STAINLESS STEEL	MK3-MK4		£115.95
4	XEXS108	EXHAUST SYSTEM-STAINLESS STEEL	MK4	TWIN SILENCER	£125.95
7	XEXS110	CLAMP-pipe to manifold	MK1-MK2		£1.95
7	XEXS111	CLAMP-pipe to manifold	MK3-MK4		£2.25
9	XEXS116	CLAMP-pipe to steady bracket	MK1-MK2		£3.95
10	XEXS117	BRACKET-exhaust brkt to clutch	MK1-MK2		£21.50
12	XEXS121	STRAP-front pipe	MK3-MK4		£1.25
15	XEXS125	BRACKET-support-pipe to body	MK1-MK2		£3.75
15	XEXS126	BRACKET-support-pipe to body	MK3-MK4		£4.25
16	XEXS127	MOUNTING-main support	MK1-MK4	USE.EXS173	-
18	XEXS130	CLAMP-silencer to pipe	MK1-MK2	U CLAMP	£0.80
18	XEXS131	CLAMP-silencer to pipe	MK3-MK4		£1.85
20	XEXS135	BUSH-rubber-silencer mounting	MK1-MK4		£0.39
30	XEXS145	TUBULAR EXHAUST MANIFOLD-mild steel	948CC	MOD TO CHASSIS REQUIRED	£157.50
30	XEXS146	TUBULAR EXHAUST MANIFOLD-mild steel	1098CC-1275CC	MOD TO CHASSIS REQUIRED	£169.95
30	XEXS147	TUBULAR EXHAUST MANIFOLD-polished s/steel	1098CC-1275CC	MOD TO CHASSIS REQUIRED	£196.00
32	XEXS148	COMPETITION GASKET-manifold	948CC-1275CC	USE WITH 3 BRANCH MANIFOLDS	£2.90
34	XEXS150	SPORTS EXHAUST SYSTEM-stainless steel	1098CC-1275CC		£185.00
35	XEXS151	FITTING KIT - sports system	1098CC-1275CC	USE WITH XEXS150	£11.25



The 1098 & 1275cc engine responds well to a large bore exhaust system improving both power and torque.

Designed specifically for Sprites & Midgets, this one-piece manifold is the same as the original Leyland competition unit.

The area close to the 1098cc chassis will need relieving to allow the manifold to clear. For maximum power use our sports exhaust XEXS150.

If fitting to a standard system, the down pipe will need to be cut to suit the new joint position.

XEXS147